

TK-980/981

SERVICE MANUAL

SUPPLEMENT IV

KENWOOD

JVC KENWOOD Corporation

© 2012-5 PRINTED IN JAPAN
B53-7028-00 (Y) PDF

This service manual has been revised due to the modification of the LCD ASSY and issues it as a supplemental manual. This service manual applies to products with B2600001 (TK-980), B2700001 (TK-981) or subsequent serial numbers. Refer to the TK-980/981 series service manual for any information which has not been covered in this manual.

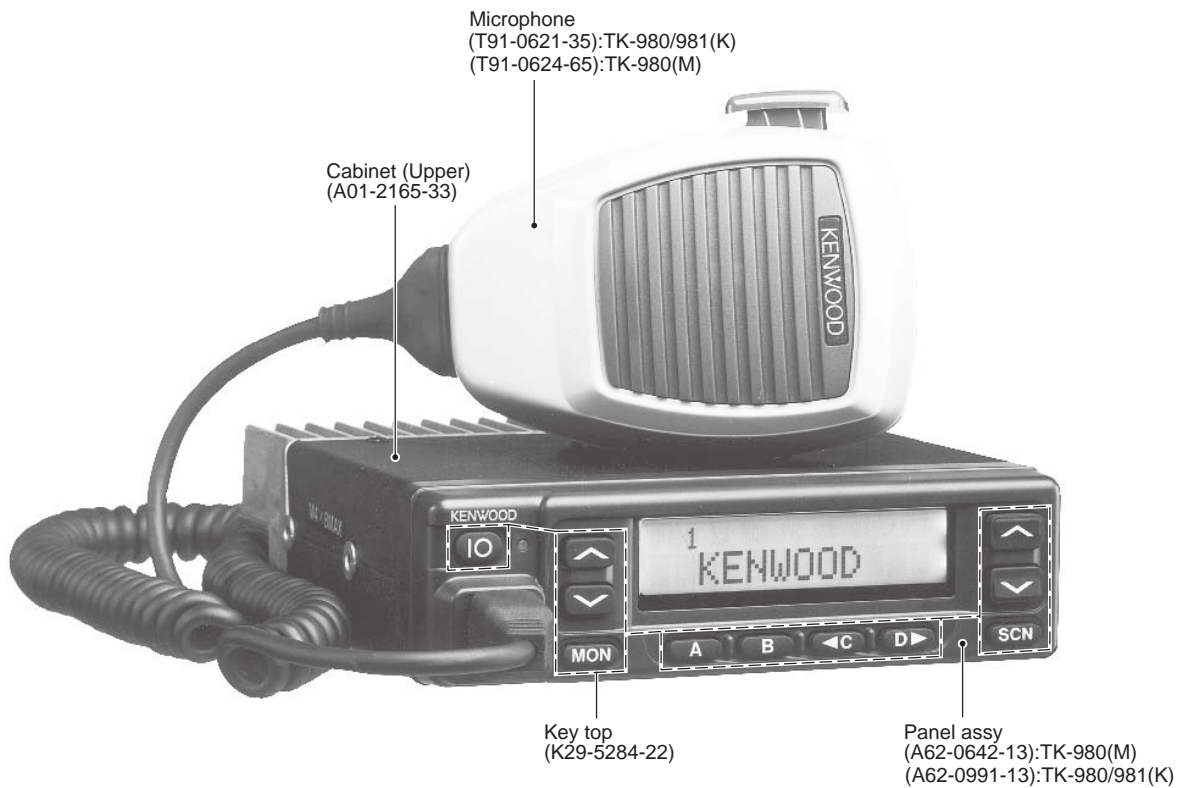

Photo is TK-980/981 K type.

CONTENTS

GENERAL	2	PC BOARD	
DISASSEMBLY FOR REPAIR	3	PLL/VCO UNIT (X58-4530-XX)	13
PARTS LIST	4	TX-RX UNIT (X57-6520-XX) (A/2)	14
EXPLODED VIEW	12	TX-RX UNIT (X57-6520-XX) (B/2)	18
		SCHEMATIC DIAGRAM	20

TK-980/981

Document Copyrights

Copyright 2012 by JVC KENWOOD Corporation. All rights reserved.

No part of this manual may be reproduced, translated, distributed, or transmitted in any form or by any means, electronic, mechanical, photocopying, recording, or otherwise, for any purpose without the prior written permission of JVC KENWOOD Corporation.

Disclaimer

While every precaution has been taken in the preparation of this manual, JVC KENWOOD Corporation assumes no responsibility for errors or omissions. Neither is any liability assumed for damages resulting from the use of the information contained herein. JVC KENWOOD Corporation reserves the right to make changes to any products herein at any time for improvement purposes.

GENERAL

SERVICE MANUAL LIST

Title	Part number	Remarks	Destination	TX-RX unit number	PCB number
TK-980	B51-8478-00	First edition	K	X57-5710-10	J72-0607-02
TK-980/981	B51-8478-10	Revised edition	K	X57-5710-XX	J72-0607-22
TK-980/981	B51-8588-00	Supplement edition S/No.30600001~	K	X57-6520-XX	J72-0816-09
TK-980/981	B51-8717-00	Supplement II edition TK-980: S/No.51000001~ TK-981: S/No.60600001~ (PDF ONLY)	K,M/K	X57-6520-XX	J72-0816-19/29 *1
TK-980/981	B51-8968-00	Supplement III edition TK-980(K): S/No.00400985~ TK-980(M): S/No.00500201~ TK-981: S/No.B1300164~ (PDF ONLY)	K,M/K	X57-6520-XX	J79-0294-09
TK-980/981	B53-7028-00	Supplement IV edition This service manual (PDF ONLY)	K,M/K	X57-6520-XX	J79-0294-09

*1 **Note** : The circuit pattern of J72-0816-19 and J72-0816-29 is the same.

DISASSEMBLY FOR REPAIR

Compatibility information

The LCD ASSY (B38-0896-15) has been discontinued by the supplier. A new LCD ASSY (B38-0949-05) has been applied to the X57-6520-XX production.

TK-980 K, M / TK-981 K TX-RX UNIT(X57-6520-XX)			
		OLD	NEW
		TX-RX UNIT: X57-6520-10/ -11 (TK-980: S/No.B25xxxxx and earlier, TK-981: S/No.B26xxxxx and earlier)	TX-RX UNIT: X57-6520-12/ -13 (TK-980: S/No.B2600001~, TK-981: S/No.B2700001~)
LCD ASSY		B38-0896-15	B38-0949-05
Microprocessor		30622MEP589GU	30622MEP599GU
Firmware	Version	Ver. 2.xx	Ver. 3.xx
	Cheksum(K type)	0AF3 (When the firmware version is Ver. 2.09.)	47C6 (When the firmware version is Ver. 3.09.)
	Cheksum(M type)	D179 (When the firmware version is Ver. 2.28.)	DED7 (When the firmware version is Ver. 3.28.)

Compatibility Chart		LCD ASSY	
		OLD	NEW
		B38-0896-15	B38-0949-05
Unit	OLD TX-RX: X57-6520-10/ -11	Available	NOT Available (The character does not appear.)
	NEW TX-RX: X57-6520-12/ -13	NOT Available (The character does not appear.)	Available

TK-980/981

PARTS LIST

* New Parts. Δ indicates safety critical components.

Parts without **Parts No.** are not supplied.

Les articles non mentionnés dans le **Parts No.** ne sont pas fournis.

Teile ohne Parts No. werden nicht geliefert.

L : Scandinavia

K : USA

P : Canada

Y : PX (Far East, Hawaii)

T : England

E : Europe

C : China

X : Australia

M : Other Areas

TK-980 / 981

TX-RX UNIT (X57-6520-XX)

Ref. No.	Address	New parts	Parts No.	Description	Destination
TK-980 / 981					
1	1A		A01-2165-33	METALLIC CABINET(UPPER)	
2	2A		A01-2166-33	METALLIC CABINET(LOWER)	
3	2A		A62-0642-13	PANEL ASSY	M
3	2A	*	A62-0991-13	PANEL ASSY	K2,K3
5	1D		B09-0235-05	CAP ACCESSORY	
6	2B	*	B38-0949-05	LCD ASSY	
7	2D	*	B62-1322-30	INSTRUCTION MANUAL	M
7	2D	*	B62-1549-10	INSTRUCTION MANUAL	K2,K3
7	2D	*	B62-1882-10	INSTRUCTION MANUAL	K2,K3
8	1C	*	B72-1487-24	MODEL NAME-PLATE	M
8	1C	*	B72-1488-34	MODEL NAME-PLATE	K3
8	1C		B72-2047-04	MODEL NAME-PLATE	K2
10	2B		E23-1136-04	GROUND TERMINAL	K2,M
11	1C	*	E30-3031-35	ANTENNA CABLE	
12	1D		E30-3339-15	DC CORD ACCESSORY	
13	1C		E30-3340-05	DC CORD	
15	1B		E37-0790-25	LEAD WIRE WITH CONNECTOR(SP)	
14	2B		E37-1441-05	FLAT CABLE(CONT-TXRX)	
-			F10-2280-12	SHIELDING COVER	
-			F10-2354-03	SHIELDING PLATE	K3
-			F10-2355-04	SHIELDING COVER	K3
17	2B		F20-1192-04	INSULATING SHEET	
18	1D		F51-0078-05	FUSE(6X30)(10A)	
20	1B,1C		G02-0791-14	FLAT SPRING(AF,APC,AVR)	
21	1B,1C		G10-1221-04	FIBROUS SHEET(SIDE)	
22	1B		G10-1222-14	FIBROUS SHEET(UP,DOWN)	
23	1A,2B		G10-1223-14	FIBROUS SHEET(SHIELD CASE)	
24	1C		G13-1468-04	CUSHION(DC CODE)	
25	1B		G13-1873-04	CUSHION(SP)	
-			G13-2102-04	CONDUCTIVE CUSHION	K3
26	2C		G53-0796-04	PACKING(PHONE JACK)	
32	3E		H52-1431-02	ITEM CARTON CASE	K2
32	3E	*	H52-1431-12	ITEM CARTON CASE	M
32	3E		H52-1432-02	ITEM CARTON CASE	K3
28	3D		H10-6618-12	POLYSTYRENE FOAMED FIXTURE(F)	
29	2E		H10-6619-12	POLYSTYRENE FOAMED FIXTURE(R)	
30	1D		H12-1391-03	INNER CARTON CASE	
31	1E		H25-0720-04	PROTECTION BAG (200X350)	
34	2D		J19-1584-15	HOLDER ACCESSORY	
35	1D		J29-0728-03	BRACKET ACCESSORY	
37	2B		K29-5284-22	KEY TOP	
A	1A,2A		N33-2606-43	OVAL HEAD MACHINE SCREW	
B	2C		N67-3008-48	PAN HEAD SEMS SCREW	
C	1A,2B		N87-2606-48	BRAZIER HEAD TAPTITE SCREW	
D	2B		N87-2612-48	BRAZIER HEAD TAPTITE SCREW	
39	2D		N99-2048-05	SCREW SET ACCESSORY	
41	1B	*	T07-0788-05	SPEAKER	
42	1D		T91-0621-35	MICROPHONE ACCESSORY	K2,K3
42	1D		T91-0624-65	MICROPHONE ACCESSORY	M

Ref. No.	Address	New parts	Parts No.	Description	Destination
TX-RX UNIT (X57-6520-XX) -12 : TK-980 -13 : TK-981					
D511			B30-2151-05	LED(RED/GREEN)	
D512-517			B30-2171-05	LED	
C1 -15			CC73GCH1H101J	CHIP C 100PF	J
C16			CS77BA1A100M	CHIP TNL 10UF	10WV
C18			CS77BA0J4R7M	CHIP TNL 4.7UF	6.3WV
C19			CC73GCH1H100D	CHIP C 10PF	D
C20 -22			CC73GCH1H101J	CHIP C 100PF	J
C23			CS77BA0J4R7M	CHIP TNL 4.7UF	6.3WV
C24			CC73GCH1H101J	CHIP C 100PF	J
C25			CS77BA0J4R7M	CHIP TNL 4.7UF	6.3WV
C27			CK73GB1H102K	CHIP C 1000PF	K
C28			CC73GCH1H220J	CHIP C 22PF	J
C29			CS77BA1A100M	CHIP TNL 10UF	10WV
C30			CK73GB1H102K	CHIP C 1000PF	K
C31			CS77BA1A100M	CHIP TNL 10UF	10WV
C32			CC73GCH1H100D	CHIP C 10PF	D
C33			CK73GB1E103K	CHIP C 0.010UF	K
C34		*	CS77AC1C220M	CHIP TNL 22UF	16WV
C35			CC73GCH1H101J	CHIP C 100PF	J
C36			CS77BA1A100M	CHIP TNL 10UF	10WV
C37			C92-0930-05	ELECTRO 100UF	16WV
C38			CS77BA0J4R7M	CHIP TNL 4.7UF	6.3WV
C39			CK73GB1E103K	CHIP C 0.010UF	K
C40			CC73GCH1H101J	CHIP C 100PF	J
C41 ,42			CS77BA1A100M	CHIP TNL 10UF	10WV
C43 ,44			CC73GCH1H101J	CHIP C 100PF	J
C45			CS77BA0J4R7M	CHIP TNL 4.7UF	6.3WV
C46			CS77MA1D010M	CHIP TNL 1.0UF	20WV
C47			CC73GCH1H101J	CHIP C 100PF	J
C48			CK73FF1C105Z	CHIP C 1.0UF	Z
C49			CC73GCH1H101J	CHIP C 100PF	J
C51			CC73GCH1H101J	CHIP C 100PF	J
C52			CC73GCH1H100D	CHIP C 10PF	D
C54			CK73GB1C104K	CHIP C 0.10UF	K
C55			CC73GCH1H030C	CHIP C 3.0PF	C
C56			CC73GCH1H101J	CHIP C 100PF	J
C57			CK73GB1E103K	CHIP C 0.010UF	K
C58			CC73GCH1H101J	CHIP C 100PF	J
C59			CC73GCH1H030C	CHIP C 3.0PF	C
C60			CC73GCH1H101J	CHIP C 100PF	J
C61			CK73GB1E103K	CHIP C 0.010UF	K
C62			CC73GCH1H030C	CHIP C 3.0PF	C
C63			CK73FF1C105Z	CHIP C 1.0UF	Z
C64			CC73GCH1H101J	CHIP C 100PF	J
C65			CK73GB1C104K	CHIP C 0.10UF	K
C66			CK73GB1E103K	CHIP C 0.010UF	K
C67			CC73GCH1H101J	CHIP C 100PF	J
C68			CK73GB1C104K	CHIP C 0.10UF	K
C70			CE32BD1E470M	CHIP EL 47UF	25WV
C71			CK73GB1C104K	CHIP C 0.10UF	K
C72 ,73			CK73GB1H102K	CHIP C 1000PF	K
C74			CE32BD1E470M	CHIP EL 47UF	25WV

PARTS LIST

TX-RX UNIT (X57-6520-XX)

Ref. No.	Address	New parts	Parts No.	Description	Desti-nation	Ref. No.	Address	New parts	Parts No.	Description	Desti-nation
C75			C92-0881-05	ELECTRO 47UF 10WV		C162			C92-0949-05	CHIP TNTL 4.7UF 16WV	
C76			CK73GB1H102K	CHIP C 1000PF K		C164			CK73GB1H471K	CHIP C 470PF K	
C77			CE32BD1E470M	CHIP EL 47UF 25WV		C166			CK73GB1C104K	CHIP C 0.10UF K	
C78			CK73GB1E103K	CHIP C 0.010UF K		C167			CC73GCH1H100D	CHIP C 10PF D	
C79			CE32BD1C471M	CHIP EL 470UF 16WV		C168			CC73GCH1H080D	CHIP C 8.0PF D	
C80			CK73GB1C104K	CHIP C 0.10UF K		C169			CK73GB1H102K	CHIP C 1000PF K	
C83			CK73FB1H473K	CHIP C 0.047UF K		C170			CC73GCH1H050C	CHIP C 5.0PF C	K3
C84			CC73GCH1H120J	CHIP C 12PF J	K2,M	C170			CC73GCH1H070B	CHIP C 7.0PF B	K2,M
C84			CC73GCH1H220J	CHIP C 22PF J	K3	C171			CC73GCH1H101J	CHIP C 100PF J	
C85			CK73GB1H102K	CHIP C 1000PF K		C172			CK73GB1C104K	CHIP C 0.10UF K	
C87			CC73GCH1H101J	CHIP C 100PF J		C173			CK73GB1E103K	CHIP C 0.010UF K	
C88			CK73GB1E103K	CHIP C 0.010UF K		C174			C92-0949-05	CHIP TNTL 4.7UF 16WV	
C89			CK73GB1H471K	CHIP C 470PF K		C175			CC73GCH1H101J	CHIP C 100PF J	K2,M
C90			CK73GB1H102K	CHIP C 1000PF K		C175,176			CC73GCH1H101J	CHIP C 100PF J	K3
C91,92			CK73GB1E103K	CHIP C 0.010UF K		C176			CC73GCH1H470J	CHIP C 47PF J	K2,M
C94			CK73GB1H471K	CHIP C 470PF K		C177			CS77BA1E010M	CHIP TNTL 1.0UF 25WV	
C96			CC73GCH1H180J	CHIP C 18PF J		C178			CC73GCH1H470J	CHIP C 47PF J	K2,M
C97			CK73GB1H102K	CHIP C 1000PF K		C179			CC73GCH1H101J	CHIP C 100PF J	K3
C98			CC73GCH1H150J	CHIP C 15PF J		C184			CS77BA1A100M	CHIP TNTL 10UF 10WV	K3
C99			CK73GB1H102K	CHIP C 1000PF K		C195-198			CK73GB1H102K	CHIP C 1000PF K	
C100			CS77BA1A100M	CHIP TNTL 10UF 10WV	K2,M	C207			CC73GCH1H101J	CHIP C 100PF J	
C102			CC73GCH1H270J	CHIP C 27PF J		C209			CC73GCH1H101J	CHIP C 100PF J	
C103			CK73GB1C104K	CHIP C 0.10UF K		C210			CC73GCH1H030C	CHIP C 3.0PF C	K3
C104			CK73GB1E103K	CHIP C 0.010UF K		C210			CC73GCH1H040C	CHIP C 4.0PF C	K2,M
C105			CS77MA1D010M	CHIP TNTL 1.0UF 20WV		C211			CC73GCH1H101J	CHIP C 100PF J	
C106			CK73GB1H102K	CHIP C 1000PF K		C212			CC73GCH1H050C	CHIP C 5.0PF C	
C107			CS77BA1A100M	CHIP TNTL 10UF 10WV		C213			CC73GCH1H010B	CHIP C 1.0PF B	
C108			CK73GB1C104K	CHIP C 0.10UF K		C214,215			CC73GCH1H101J	CHIP C 100PF J	
C109,110			CK73GB1H102K	CHIP C 1000PF K		C216			CC73GCH1H010B	CHIP C 1.0PF B	K3
C111			CC73GCH1H101J	CHIP C 100PF J		C216			CC73GCH1H1R5B	CHIP C 1.5PF B	K2,M
C112			CK73GB1H102K	CHIP C 1000PF K		C217			CK73GB1H102K	CHIP C 1000PF K	
C113			CK73GB1E103K	CHIP C 0.010UF K		C218			CC73GCH1H101J	CHIP C 100PF J	
C114		*	CS77MA1C3R3M	CHIP TNTL 3.3UF 16WV		C219			CC73GCH1H110J	CHIP C 11PF J	K2,M
C115			CK73GB1H102K	CHIP C 1000PF K		C219			CC73GCH1H120J	CHIP C 12PF J	K3
C116			CS77BA0J4R7M	CHIP TNTL 4.7UF 6.3WV		C220			CC73GCH1H101J	CHIP C 100PF J	
C117			CK73GB1E103K	CHIP C 0.010UF K		C221			CK73GB1H102K	CHIP C 1000PF K	
C118			CK73GB1C104K	CHIP C 0.10UF K		C222			CC73GCH1H101J	CHIP C 100PF J	
C121		*	CS77MA1C3R3M	CHIP TNTL 3.3UF 16WV		C224			CK73GB1H102K	CHIP C 1000PF K	
C123			CK73GB1C104K	CHIP C 0.10UF K		C227			CK73GB1H103K	CHIP C 0.010UF K	
C124,125			CK73GB1H102K	CHIP C 1000PF K		C228			CK73GB1H102K	CHIP C 1000PF K	
C126			CK73GB1C104K	CHIP C 0.10UF K		C229			CK73GB1H103K	CHIP C 0.010UF K	
C127			CK73GB1E103K	CHIP C 0.010UF K		C234			CC73GCH1H101J	CHIP C 100PF J	K3
C128,129			CC73GCH1H470J	CHIP C 47PF J		C234			CC73GCH1H150J	CHIP C 15PF J	K2,M
C131			CC73GCH1H101J	CHIP C 100PF J		C235			CC73GCH1H020B	CHIP C 2.0PF B	
C132			CK73GB1C104K	CHIP C 0.10UF K		C236			CC73GCH1H101J	CHIP C 100PF J	
C134			CK73FB1C224K	CHIP C 0.22UF K		C240			CK73GB1E103K	CHIP C 0.010UF K	
C136			CK73FB1C224K	CHIP C 0.22UF K		C245			CC73GCH1H101J	CHIP C 100PF J	
C137			CK73GB1H471K	CHIP C 470PF K		C246			CS77MA1V0R1M	CHIP TNTL 0.1UF 35WV	
C142,143			CK73GB1H471K	CHIP C 470PF K		C247			CC73GCH1H101J	CHIP C 100PF J	
C144			CK73GB1H102K	CHIP C 1000PF K		C249			CC73GCH1H100D	CHIP C 10PF D	
C150			CC73GCH1H220J	CHIP C 22PF J		C252			CK73GB1H102K	CHIP C 1000PF K	
C151			CK73GB1H102K	CHIP C 1000PF K		C253			CC73FCH1H060D	CHIP C 6.0PF D	K2,M
C152			C92-0777-05	ELECTRO 1000UF 25WV		C253			CC73FCH1H080D	CHIP C 8.0PF D	K3
C153			CC73GCH1H100D	CHIP C 10PF D		C255			CC73FCH1H040C	CHIP C 4.0PF C	K3
C155			CK73GB1H102K	CHIP C 1000PF K		C255			CC73FCH1H100D	CHIP C 10PF D	K2,M
C156			CK73GB1E103K	CHIP C 0.010UF K		C256			CK73GB1H102K	CHIP C 1000PF K	
C157			CK73GB1C104K	CHIP C 0.10UF K		C258			CK73GB1C104K	CHIP C 0.10UF K	
C158,159			CC73GCH1H040C	CHIP C 4.0PF C		C262			CE32BD1E470M	CHIP EL 47UF 25WV	
C160			CK73GB1C104K	CHIP C 0.10UF K		C263			CK73GB1H102K	CHIP C 1000PF K	
C161			CC73GCH1H101J	CHIP C 100PF J		C264			CK73GB1C104K	CHIP C 0.10UF K	

K2: TK-980(K) M: TK-980(M) K3: TK-981(K)

PARTS LIST

TX-RX UNIT (X57-6520-XX)

Ref. No.	Address	New parts	Parts No.	Description	Destination	Ref. No.	Address	New parts	Parts No.	Description	Destination
C265			C93-0550-05	CHIP C 1.0PF C	K2,M	C460			CK73GB1H103K	CHIP C 0.010UF K	
C265,266			C93-0550-05	CHIP C 1.0PF C	K3	C461-464			CK73GB1C104K	CHIP C 0.10UF K	
C266			C93-0553-05	CHIP C 3.0PF C	K2,M	C465-471			CC73GCH1H101J	CHIP C 100PF J	K3
C267			C93-0568-05	CHIP C 47PF J		C501			CK73GB1H471K	CHIP C 470PF K	
C268			CC73FCH1H010C	CHIP C 1.0PF C	K3	C503,504			CK73GB1H471K	CHIP C 470PF K	
C268			CC73FCH1H470J	CHIP C 47PF J	K2,M	C505			CK73GB1C683K	CHIP C 0.068UF K	
C269			C93-0560-05	CHIP C 10PF D		C506			CK73GB1E123K	CHIP C 0.012UF K	
C271			C93-0550-05	CHIP C 1.0PF C		C509			CK73GB1H222K	CHIP C 2200PF K	
C272			CC73GCH1H010C	CHIP C 1.0PF C		C510			CS77BA0J4R7M	CHIP TNTL 4.7UF 6.3WV	
C273			C93-0552-05	CHIP C 2.0PF C	K3	C511			CK73GB1H103K	CHIP C 0.010UF K	
C273			C93-0553-05	CHIP C 3.0PF C	K2,M	C512			CK73GB1H471K	CHIP C 470PF K	
C274			CC73GCH1H221J	CHIP C 220PF J		C513			CK73GB1H102K	CHIP C 1000PF K	
C275		*	CS77MA1VR22M	CHIP TNTL 0.22UF 35WV		C514			CK73GB1H152K	CHIP C 1500PF K	
C276		*	CS77AA1D4R7M	CHIP TNTL 4.7UF 20WV	K2,M	C515			CK73GB1C104K	CHIP C 0.10UF K	
C276		*	CS77MA1D2R2M	CHIP TNTL 2.2UF 20WV	K3	C516,517			CK73GB1H103K	CHIP C 0.010UF K	
C284			CC73GCH1H470J	CHIP C 47PF J		C518			CK73GB1H102K	CHIP C 1000PF K	
C286			CC73GCH1H470J	CHIP C 47PF J		C519			CS77BA0J4R7M	CHIP TNTL 4.7UF 6.3WV	
C289			CK73GB1E103K	CHIP C 0.010UF K		C520			CC73GCH1H121J	CHIP C 120PF J	
C307			CK73GB1H103K	CHIP C 0.010UF K		C521,522			CK73GB1C104K	CHIP C 0.10UF K	
C308			CC73GCH1H2R5B	CHIP C 2.5PF B		C523			CK73GB1H103K	CHIP C 0.010UF K	
C309			CC73GCH1H0R5B	CHIP C 0.5PF B	K3	C524			CK73GB1C104K	CHIP C 0.10UF K	
C309			CC73GCH1H010B	CHIP C 1.0PF B	K2,M	C525			CK73GB1H103K	CHIP C 0.010UF K	
C310			CC73GCH1H1R5B	CHIP C 1.5PF B	K3	C526			CK73GB1C104K	CHIP C 0.10UF K	
C310			CC73GCH1H2R5B	CHIP C 2.5PF B	K2,M	C527			CK73GB1C333K	CHIP C 0.033UF K	
C314			CS77MA1V0R1M	CHIP TNTL 0.1UF 35WV		C528			CK73GB1H102K	CHIP C 1000PF K	
C317			CC73GCH1H101J	CHIP C 100PF J		C529			CK73GB1H562K	CHIP C 5600PF K	
C320			CS77AA1E010M	CHIP TNTL 1.0UF 25WV	K3	C531			CK73GB1H562K	CHIP C 5600PF K	
C320			CS77MA1A6R8M	CHIP TNTL 6.8UF 10WV	K2,M	C533			CK73GB1H562K	CHIP C 5600PF K	
C321			CC73GCH1H040C	CHIP C 4.0PF C		C535			CK73GB1H102K	CHIP C 1000PF K	
C322			CS77AA1E010M	CHIP TNTL 1.0UF 25WV	K3	C536			CC73GCH1H030C	CHIP C 3.0PF C	
C322			CS77MA1A6R8M	CHIP TNTL 6.8UF 10WV	K2,M	C537			CK73GB1H272K	CHIP C 2700PF K	
C325			CS77AA1DR68M	CHIP TNTL 0.68UF 20WV	K2,M	C539			CK73GB1H272K	CHIP C 2700PF K	
C325			CS77MA1ER47M	CHIP TNTL 0.47UF 25WV	K3	C540			CC73GCH1H271J	CHIP C 270PF J	
C326			CK73FB1C154K	CHIP C 0.15UF K		C541			CC73GCH1H151J	CHIP C 150PF J	
C327			CC73GCH1H101J	CHIP C 100PF J		C542			CC73GCH1H271J	CHIP C 270PF J	
C328			CK73GB1H471K	CHIP C 470PF K		C543			CK73GB1H272K	CHIP C 2700PF K	
C330			CC73FCH1H150J	CHIP C 15PF J	K2,M	C544			CC73GCH1H030C	CHIP C 3.0PF C	
C330			CC73FCH1H470J	CHIP C 47PF J	K3	C545			CK73GB1H102K	CHIP C 1000PF K	
C331,332			CC73GCH1H101J	CHIP C 100PF J		C546			CK73GB1H122K	CHIP C 1200PF K	
C401-405			CC73GCH1H020B	CHIP C 2.0PF B		C547			CK73GB1H102K	CHIP C 1000PF K	
C437			CK73GB1H102K	CHIP C 1000PF K		C548			CS77BA0J220M	CHIP TNTL 22UF 6.3WV	
C438			CC73GCH1H220J	CHIP C 22PF J		C549			CK73GB1C104K	CHIP C 0.10UF K	
C440			CK73GB1C104K	CHIP C 0.10UF K		C550			CC73GCH1H101J	CHIP C 100PF J	
C441			CC73GCH1H101J	CHIP C 100PF J		C552			CK73GB1C333K	CHIP C 0.033UF K	
C442			CK73GB1H102K	CHIP C 1000PF K		C553			CK73GB1H472K	CHIP C 4700PF K	
C443			CK73GB1C104K	CHIP C 0.10UF K		C554-558			CK73GB1C104K	CHIP C 0.10UF K	
C444			CC73GCH1H101J	CHIP C 100PF J		C559			CK73GB1H102K	CHIP C 1000PF K	
C445			CK73GB1H102K	CHIP C 1000PF K		C560			CS77BA0J4R7M	CHIP TNTL 4.7UF 6.3WV	
C446			CK73GB1C104K	CHIP C 0.10UF K		C561			CK73GB1H102K	CHIP C 1000PF K	
C447			CK73GB1H102K	CHIP C 1000PF K		C562,563			CK73GB1H472K	CHIP C 4700PF K	
C448			CK73GB1H103K	CHIP C 0.010UF K		C564			CK73GB1E223K	CHIP C 0.022UF K	
C449			CC73GCH1H560J	CHIP C 56PF J		C565			CK73GB1H102K	CHIP C 1000PF K	
C450			CK73GB1H102K	CHIP C 1000PF K		C566			CC73GCH1H101J	CHIP C 100PF J	
C451			CC73GCH1H101J	CHIP C 100PF J		C567			CK73GB1E223K	CHIP C 0.022UF K	
C453			CK73GB1H102K	CHIP C 1000PF K		C568			CS77BA0J220M	CHIP TNTL 22UF 6.3WV	
C454			CK73GB1H103K	CHIP C 0.010UF K		C569			CC73GCH1H470J	CHIP C 47PF J	
C455			CC73GCH1H101J	CHIP C 100PF J		C570			CK73GB1C104K	CHIP C 0.10UF K	
C456			CK73GB1H102K	CHIP C 1000PF K		C571			CK73GB1H102K	CHIP C 1000PF K	
C457			CK73GB1C104K	CHIP C 0.10UF K		C572			CK73FB1H563K	CHIP C 0.055UF K	
C458,459			CC73GCH1H101J	CHIP C 100PF J		C574			CK73GB1C104K	CHIP C 0.10UF K	

PARTS LIST

TX-RX UNIT (X57-6520-XX)

Ref. No.	Address	New parts	Parts No.	Description	Destination	Ref. No.	Address	New parts	Parts No.	Description	Destination
C575			CK73FB1C334K	CHIP C 0.33UF K		J1	2C		E11-0442-05	3.5D PHONE JACK(EXT SP)	
C576			CK73GB1C473K	CHIP C 0.047UF K		J501	1B		E58-0522-05	MODULAR JACK(MIC)	
C577			CK73GB1C104K	CHIP C 0.10UF K		-			J31-0543-05	COLLAR(LH-5-1.5)	
C578			CK73GB1H103K	CHIP C 0.010UF K		CF1			L72-0986-05	CERAMIC FILTER(455KHZ)	K3
C579			CK73GB1H472K	CHIP C 4700PF K		CF1			L72-0998-05	CERAMIC FILTER(455KHZ)	K2,M
C580			CK73GB1H102K	CHIP C 1000PF K		L1			L41-4795-33	SMALL FIXED INDUCTOR(4.7UH)	
C582			CK73GB1H103K	CHIP C 0.010UF K		L3 ,4			L40-1875-92	SMALL FIXED INDUCTOR(18NH)	
C583			CK73GB1H102K	CHIP C 1000PF K		L5			L41-1095-33	SMALL FIXED INDUCTOR(1.0UH)	
C584			CK73GB1H471K	CHIP C 470PF K		L6			L34-4787-05	COIL	
C592			CK73GB1H102K	CHIP C 1000PF K		L8			L92-0138-05	CHIP FERRITE	
C593			CK73GB1H223K	CHIP C 0.022UF K	K3	L9			L40-8265-92	SMALL FIXED INDUCTOR(8.2NH)	
C593			CK73GB1H473K	CHIP C 0.047UF K	K2,M	L10			L41-1095-33	SMALL FIXED INDUCTOR(1.0UH)	
C594,595			CC73GCH1H150J	CHIP C 15PF J	K3	L205			L40-1075-92	SMALL FIXED INDUCTOR(10NH)	
C594,595			CC73GCH1H180J	CHIP C 18PF J	K2,M	L206			L40-6865-92	SMALL FIXED INDUCTOR(6.8NH)	K3
C596			CC73GCH1H040B	CHIP C 4.0PF B	K2,M	L206			L40-8265-92	SMALL FIXED INDUCTOR(8.2NH)	K2,M
C597			CK73GB1H103K	CHIP C 0.010UF K	K2,M	L208			L40-4763-92	SMALL FIXED INDUCTOR(4.7NH)	
C598,599			CC73GCH1H101J	CHIP C 100PF J		L209			L40-8265-92	SMALL FIXED INDUCTOR(8.2NH)	
C600,601			CK73GB1H102K	CHIP C 1000PF K		L210			L40-3985-45	SMALL FIXED INDUCTOR(0.39UH)	
C602			CK73GB1H103K	CHIP C 0.010UF K		L211			L40-6885-45	SMALL FIXED INDUCTOR(0.68UH)	
C603			CK73GB1C104K	CHIP C 0.10UF K		L218			L40-1075-38	SMALL FIXED INDUCTOR(10NH)	
C604			CS77BA0J100M	CHIP TNTL 10UF 6.3WV		L220			L34-1306-15	AIR-CORE COIL(5.5T)	
C605			CK73GB1H102K	CHIP C 1000PF K		L221			L34-1317-05	AIR-CORE COIL(3.5T)	
C606			CK73GB1H472K	CHIP C 4700PF K		L222,223			L34-1307-05	AIR-CORE COIL(2T)	K2,M
C607			CK73GB1C104K	CHIP C 0.10UF K		L222,223			L34-1313-05	AIR-CORE COIL(2T)	K3
C608			CK73GB1H392K	CHIP C 3900PF K		L224			L34-1306-15	AIR-CORE COIL(5.5T)	
C609,610			CK73GB1H103K	CHIP C 0.010UF K		L225			L92-0179-05	CHIP FERRITE	
C612			CK73GB1H103K	CHIP C 0.010UF K		L226			L40-1075-38	SMALL FIXED INDUCTOR(10NH)	
C613			CS77AA1A4R7M	CHIP TNTL 4.7UF 10WV	K2,M	L229			L34-1308-15	AIR-CORE COIL(2T)	
C613			CS77BA1A4R7M	CHIP TNTL 4.7UF 10WV	K3	L230,231			L79-1910-05	DIELECTRIC FILTER(860MHZ)	K2,M
C614			CK73GB1H102K	CHIP C 1000PF K		L230,231			L79-1911-05	DIELECTRIC FILTER(938MHZ)	K3
C616			CK73GB1H102K	CHIP C 1000PF K		L300			L40-1563-92	SMALL FIXED INDUCTOR(1.5NH)	
C617			CC73GCH1H101J	CHIP C 100PF J		L301			L40-4763-92	SMALL FIXED INDUCTOR(4.7NH)	
C620			CC73GCH1H101J	CHIP C 100PF J		L303,304			L40-2763-92	SMALL FIXED INDUCTOR(2.7NH)	
C622,623			CK73GB1H102K	CHIP C 1000PF K		L305			L92-0179-05	CHIP FERRITE	
C624			CC73GCH1H101J	CHIP C 100PF J		L310-312			L40-8265-92	SMALL FIXED INDUCTOR(8.2NH)	
C625			CK73GB1H102K	CHIP C 1000PF K		L313			L92-0140-05	CHIP FERRITE	
C626			CC73GCH1H101J	CHIP C 100PF J		L501-508			L92-0138-05	CHIP FERRITE	
C627			CK73GB1H102K	CHIP C 1000PF K		X1			L77-3028-05	TCXO(16.8MHZ)	
C628			CC73GCH1H101J	CHIP C 100PF J		X2			L77-1762-05	CRYSTAL RESONATOR(44.395MHZ)	
C630			CK73GB1H102K	CHIP C 1000PF K		X501			L77-1708-15	CRYSTAL RESONATOR(3.579545MHZ)	
C631-634			CC73GCH1H101J	CHIP C 100PF J		X502			L77-3038-05	CRYSTAL RESONATOR(9.8304MHZ)	
C714			CC73GCH1H331J	CHIP C 330PF J		XF1			L71-0525-05	MCF(44.85MHZ)	K2,M
C715			CK73GB1H102K	CHIP C 1000PF K		XF1			L71-0583-05	MCF(44.85MHZ)	K3
C718			CS77BA0J220M	CHIP TNTL 22UF 6.3WV		R1			RK73GB2A102J	CHIP R 1.0K J 1/10W	
C720			CC73GCH1H470J	CHIP C 47PF J		R2			RK73GB2A000J	CHIP R 0 J 1/10W	
C722,723			CC73GCH1H221J	CHIP C 220PF J		R3			RK73GB2A101J	CHIP R 100 J 1/10W	
C726			CK73GB1C104K	CHIP C 0.10UF K		R4			RK73GB2A102J	CHIP R 1.0K J 1/10W	
C728			CS77MP0J100M	CHIP TNTL 10UF 6.3WV		R6 ,7			RK73GB2A000J	CHIP R 0 J 1/10W	
C729			CK73GB1H103K	CHIP C 0.010UF K		R8			RK73GB2A102J	CHIP R 1.0K J 1/10W	
C730			CK73HB1E103K	CHIP C 0.010UF K		R9			RK73GB2A000J	CHIP R 0 J 1/10W	
CN1			E41-2834-05	PIN ASSY(8P)		R10 ,11			RK73GB2A102J	CHIP R 1.0K J 1/10W	
CN2	*		E41-3085-05	PIN ASSY(3P)		R12			RK73GB2A000J	CHIP R 0 J 1/10W	
CN3			E41-1683-05	PIN ASSY(3P)		R14			RK73GB2A473J	CHIP R 47K J 1/10W	
CN4	*		E41-3085-05	PIN ASSY(3P)		R15			RK73GB2A103J	CHIP R 10K J 1/10W	
CN5			E41-1683-05	PIN ASSY(3P)		R16			RK73GB2A333J	CHIP R 33K J 1/10W	
CN6			E41-1682-05	PIN ASSY(2P)		R17			RK73GB2A000J	CHIP R 0 J 1/10W	
CN7	*		E40-6804-05	FLAT CABLE CONNECTOR(33P)		R19			RK73GB2A153J	CHIP R 15K J 1/10W	
CN501			E40-6452-05	FLAT CABLE CONNECTOR(10P)		R20			RK73GB2A104J	CHIP R 100K J 1/10W	
CN502	*		E40-6804-05	FLAT CABLE CONNECTOR(33P)							

K2: TK-980(K) M: TK-980(M) K3: TK-981(K)

PARTS LIST

TX-RX UNIT (X57-6520-XX)

Ref. No.	Address	New parts	Parts No.	Description	Destination	Ref. No.	Address	New parts	Parts No.	Description	Destination
R21			RK73GB2A563J	CHIP R 56K J 1/10W		R99			RK73GB2A152J	CHIP R 1.5K J 1/10W	
R22			RK73GB2A104J	CHIP R 100K J 1/10W		R100			RK73GB2A151J	CHIP R 150 J 1/10W	K3
R23			RK73GB2A224J	CHIP R 220K J 1/10W		R100			RK73GB2A331J	CHIP R 330 J 1/10W	K2,M
R25			RK73GB2A394J	CHIP R 390K J 1/10W		R101			RK73FB2B470J	CHIP R 47 J 1/8W	
R26			RK73GB2A104J	CHIP R 100K J 1/10W		R102			RK73FB2B102J	CHIP R 1.0K J 1/8W	
R27			RK73GB2A473J	CHIP R 47K J 1/10W		R103			RK73FB2B223J	CHIP R 22K J 1/8W	
R29			RK73GB2A220J	CHIP R 22 J 1/10W		R104			RK73FB2B473J	CHIP R 47K J 1/8W	
R30			RK73GB2A224J	CHIP R 220K J 1/10W		R105	*		R92-3630-05	CHIP R 3.9K J 1/8W	
R31			RK73GB2A104J	CHIP R 100K J 1/10W		R106			RK73GB2A000J	CHIP R 0 J 1/10W	
R32 ,33			RK73GB2A474J	CHIP R 470K J 1/10W		R107			RK73GB2A473J	CHIP R 47K J 1/10W	
R34			RK73GB2A000J	CHIP R 0 J 1/10W		R109			RK73FB2B000J	CHIP R 0 J 1/8W	
R36			RK73GB2A103J	CHIP R 10K J 1/10W		R110			RK73GB2A470J	CHIP R 47 J 1/10W	
R37			RK73GB2A000J	CHIP R 0 J 1/10W		R111			RK73GB2A472J	CHIP R 4.7K J 1/10W	
R39			RK73GB2A101J	CHIP R 100 J 1/10W		R112,113	*		R92-3629-05	CHIP R 4.7K J 1/8W	
R40			RK73GB2A472J	CHIP R 4.7K J 1/10W		R116			RK73GB2A473J	CHIP R 47K J 1/10W	
R41			RK73GB2A183J	CHIP R 18K J 1/10W		R118			RK73GB2A392J	CHIP R 3.9K J 1/10W	K2,M
R42			RK73GB2A333J	CHIP R 33K J 1/10W		R119			RK73GB2A103J	CHIP R 10K J 1/10W	
R44 ,45			RK73GB2A154J	CHIP R 150K J 1/10W		R120	*		R92-3629-05	CHIP R 4.7K J 1/8W	
R46			RK73GB2A104J	CHIP R 100K J 1/10W		R121			RK73GB2A472J	CHIP R 4.7K J 1/10W	
R47			RK73GB2A473J	CHIP R 47K J 1/10W		R122			RK73FB2B272J	CHIP R 2.7K J 1/8W	
R48			RK73GB2A123J	CHIP R 12K J 1/10W		R124			RK73GB2A223J	CHIP R 22K J 1/10W	
R49 ,50			RK73GB2A103J	CHIP R 10K J 1/10W		R127			R92-2682-05	CHIP R 0.22 B 1/8W	
R52			RK73GB2A104J	CHIP R 100K J 1/10W		R128			RK73GB2A223J	CHIP R 22K J 1/10W	
R53			RK73GB2A000J	CHIP R 0 J 1/10W		R129			RK73GB2A100J	CHIP R 10 J 1/10W	
R54			RK73GB2A154J	CHIP R 150K J 1/10W		R132			RK73GB2A104J	CHIP R 100K J 1/10W	
R55			RK73GB2A104J	CHIP R 100K J 1/10W		R134			RK73GB2A473J	CHIP R 47K J 1/10W	
R56			RK73GB2A103J	CHIP R 10K J 1/10W		R135			RK73RB2H151J	CHIP R 150 J 1/2W	
R57			RK73GB2A473J	CHIP R 47K J 1/10W		R137			RK73GB2A473J	CHIP R 47K J 1/10W	
R58			RK73GB2A102J	CHIP R 1.0K J 1/10W		R139			RK73GB2A102J	CHIP R 1.0K J 1/10W	
R60			RK73GB2A472J	CHIP R 4.7K J 1/10W		R140			RK73GB2A000J	CHIP R 0 J 1/10W	
R61			RK73GB2A103J	CHIP R 10K J 1/10W		R141			RK73GB2A104J	CHIP R 100K J 1/10W	
R62			RK73GB2A101J	CHIP R 100 J 1/10W		R143			RK73GB2A102J	CHIP R 1.0K J 1/10W	
R63 -65			RK73GB2A000J	CHIP R 0 J 1/10W		R144			RK73GB2A223J	CHIP R 22K J 1/10W	
R66			RK73GB2A682J	CHIP R 6.8K J 1/10W		R145			RK73GB2A104J	CHIP R 100K J 1/10W	
R67			RK73GB2A470J	CHIP R 47 J 1/10W		R146			RK73RB2H471J	CHIP R 470 J 1/2W	
R69			RK73GB2A102J	CHIP R 1.0K J 1/10W		R148			RK73FB2B472J	CHIP R 4.7K J 1/8W	
R70 -73			RK73GB2A000J	CHIP R 0 J 1/10W		R150			RK73FB2B000J	CHIP R 0 J 1/8W	
R74			RK73GB2A473J	CHIP R 47K J 1/10W		R151-153			RK73GB2A000J	CHIP R 0 J 1/10W	
R75			RK73GB2A102J	CHIP R 1.0K J 1/10W		R154			RK73GB2A103J	CHIP R 10K J 1/10W	
R76			RK73GB2A153J	CHIP R 15K J 1/10W		R155			RK73GB2A333J	CHIP R 33K J 1/10W	
R77			RK73GB2A333J	CHIP R 33K J 1/10W		R156			RK73GB2A471J	CHIP R 470 J 1/10W	
R78			RK73GB2A104J	CHIP R 100K J 1/10W		R157			RK73GB2A101J	CHIP R 100 J 1/10W	
R79			RK73GB2A180J	CHIP R 18 J 1/10W	K3	R158,159			RK73GB2A000J	CHIP R 0 J 1/10W	
R79			RK73GB2A390J	CHIP R 39 J 1/10W	K2,M	R160			RK73GB2A105J	CHIP R 1.0M J 1/10W	
R80			RK73GB2A473J	CHIP R 47K J 1/10W		R163			RK73GB2A104J	CHIP R 100K J 1/10W	
R82 ,83			RK73GB2A151J	CHIP R 150 J 1/10W	K2,M	R166			RK73GB2A000J	CHIP R 0 J 1/10W	
R82 ,83			RK73GB2A271J	CHIP R 270 J 1/10W	K3	R168			RK73GB2A000J	CHIP R 0 J 1/10W	
R85			RK73GB2A821J	CHIP R 820 J 1/10W		R170,171			RK73GB2A000J	CHIP R 0 J 1/10W	
R86 ,87			RK73GB2A000J	CHIP R 0 J 1/10W		R172			RK73GB2A221J	CHIP R 220 J 1/10W	
R88			RK73EB2E181J	CHIP R 180 J 1/4W		R176			RK73FB2B000J	CHIP R 0 J 1/8W	
R89			RK73EB2E151J	CHIP R 150 J 1/4W		R181,182			RK73EB2E000J	CHIP R 0 J 1/4W	
R90			RK73GB2A2R2J	CHIP R 2.2 J 1/10W		R183			R92-2682-05	CHIP R 0.22 B 1/8W	
R91			RK73GB2A472J	CHIP R 4.7K J 1/10W		R184			RK73EB2E000J	CHIP R 0 J 1/4W	K2,M
R92			RK73FB2B472J	CHIP R 4.7K J 1/8W		R209			RK73GB2A103J	CHIP R 10K J 1/10W	
R93			RK73FB2B470J	CHIP R 47 J 1/8W		R210			RK73GB2A473J	CHIP R 47K J 1/10W	
R94			RK73GB2A000J	CHIP R 0 J 1/10W		R211			RK73GB2A101J	CHIP R 100 J 1/10W	
R95			RK73FB2B154J	CHIP R 150K J 1/8W		R212			RK73GB2A5R6J	CHIP R 5.6 J 1/10W	
R96			RK73GB2A181J	CHIP R 180 J 1/10W	K3	R214			RK73GB2A221J	CHIP R 220 J 1/10W	
R96			RK73GB2A331J	CHIP R 330 J 1/10W	K2,M	R217			RK73GB2A101J	CHIP R 100 J 1/10W	
R97 ,98			RK73GB2A473J	CHIP R 47K J 1/10W		R218			RK73GB2A473J	CHIP R 47K J 1/10W	

PARTS LIST

TX-RX UNIT (X57-6520-XX)

Ref. No.	Address	New parts	Parts No.	Description	Destination	Ref. No.	Address	New parts	Parts No.	Description	Destination
R219			RK73GB2A273J	CHIP R 27K J 1/10W		R518			RN73GH1J333D	CHIP R 33K D 1/16W	
R220			RK73GB2A473J	CHIP R 47K J 1/10W		R519			RN73GH1J913D	CHIP R 91K D 1/16W	
R221			RK73GB2A153J	CHIP R 15K J 1/10W		R520			RN73GH1J683D	CHIP R 68K D 1/16W	
R223			RK73GB2A102J	CHIP R 1.0K J 1/10W		R521			RK73GB2A105J	CHIP R 1.0M J 1/10W	
R236			RK73GB2A470J	CHIP R 47 J 1/10W		R522			RN73GH1J913D	CHIP R 91K D 1/16W	
R237			RK73GB2A153J	CHIP R 15K J 1/10W		R523			RK73GB2A154J	CHIP R 150K J 1/10W	
R239			RK73GB2A154J	CHIP R 150K J 1/10W		R524			RN73GH1J274D	CHIP R 270K D 1/16W	
R240			RK73GB2A333J	CHIP R 33K J 1/10W		R525			RK73GB2A334J	CHIP R 330K J 1/10W	
R247		*	RK73RB2H390J	CHIP R 39 J 1/2W		R526			RK73GB2A154J	CHIP R 150K J 1/10W	
R248,249			RK73RB2H121J	CHIP R 120 J 1/2W	K2,M	R527			RK73GB2A103J	CHIP R 10K J 1/10W	
R248,249			RK73RB2H151J	CHIP R 150 J 1/2W	K3	R528			RK73GB2A153J	CHIP R 15K J 1/10W	
R250			RK73GB2A470J	CHIP R 47 J 1/10W		R529			RK73GB2A000J	CHIP R 0 J 1/10W	
R251			RK73GB2A474J	CHIP R 470K J 1/10W		R530			RK73GB2A394J	CHIP R 390K J 1/10W	
R252			RK73RB2H000J	CHIP R 0 J 1/2W		R531			RK73GB2A473J	CHIP R 47K J 1/10W	
R253,254			RK73GB2A821J	CHIP R 820 J 1/10W		R532			RK73GB2A334J	CHIP R 330K J 1/10W	
R255,256			R92-1308-05	CHIP R 22 J 1W		R533			RK73GB2A000J	CHIP R 0 J 1/10W	
R257,258			RK73FB2B000J	CHIP R 0 J 1/8W		R535			RK73GB2A155J	CHIP R 1.5M J 1/10W	
R260			RK73FB2B153J	CHIP R 15K J 1/8W		R536			RN73GH1J682D	CHIP R 6.8K D 1/16W	
R261			RK73FB2B182J	CHIP R 1.8K J 1/8W		R537,538			RK73GB2A473J	CHIP R 47K J 1/10W	
R306			RK73GB2A102J	CHIP R 1.0K J 1/10W	K2,M	R540			RK73GB2A474J	CHIP R 470K J 1/10W	
R306			RK73GB2A182J	CHIP R 1.8K J 1/10W	K3	R541			RK73GB2A274J	CHIP R 270K J 1/10W	
R308			RK73GB2A101J	CHIP R 100 J 1/10W		R542			RN73GH1J683D	CHIP R 68K D 1/16W	
R309			RK73GB2A104J	CHIP R 100K J 1/10W	K3	R544			RK73GB2A101J	CHIP R 100 J 1/10W	
R309			RK73GB2A333J	CHIP R 33K J 1/10W	K2,M	R545			RK73GB2A182J	CHIP R 1.8K J 1/10W	
R310			RK73GB2A103J	CHIP R 10K J 1/10W	K2,M	R546			RK73GB2A224J	CHIP R 220K J 1/10W	
R310			RK73GB2A473J	CHIP R 47K J 1/10W	K3	R547			RK73GB2A103J	CHIP R 10K J 1/10W	
R311			RK73GB2A561J	CHIP R 560 J 1/10W		R548			RK73GB2A183J	CHIP R 18K J 1/10W	
R312			RK73GB2A222J	CHIP R 2.2K J 1/10W	K3	R550			RN73GH1J682D	CHIP R 6.8K D 1/16W	
R312			RK73GB2A471J	CHIP R 470 J 1/10W	K2,M	R551			RK73GB2A223J	CHIP R 22K J 1/10W	
R315			RK73GB2A103J	CHIP R 10K J 1/10W	K3	R552			RK73GB2A334J	CHIP R 330K J 1/10W	
R315			RK73GB2A473J	CHIP R 47K J 1/10W	K2,M	R553			RK73GB2A102J	CHIP R 1.0K J 1/10W	
R316,317			RK73GB2A000J	CHIP R 0 J 1/10W		R554			RK73GB2A332J	CHIP R 3.3K J 1/10W	
R318			RK73GB2A331J	CHIP R 330 J 1/10W	K3	R555			RK73GB2A394J	CHIP R 390K J 1/10W	
R318			RK73GB2A391J	CHIP R 390 J 1/10W	K2,M	R556			RK73GB2A223J	CHIP R 22K J 1/10W	
R319			RK73GB2A102J	CHIP R 1.0K J 1/10W		R558			RK73GB2A000J	CHIP R 0 J 1/10W	
R321			RK73GB2A470J	CHIP R 47 J 1/10W		R562			RK73GB2A273J	CHIP R 27K J 1/10W	
R323			RK73GB2A470J	CHIP R 47 J 1/10W	K2,M	R564			RK73GB2A000J	CHIP R 0 J 1/10W	
R323			RK73GB2A680J	CHIP R 68 J 1/10W	K3	R566			RK73GB2A470J	CHIP R 47 J 1/10W	
R408			RK73GB2A000J	CHIP R 0 J 1/10W		R567			RK73GB2A220J	CHIP R 22 J 1/10W	
R411			RK73GB2A000J	CHIP R 0 J 1/10W		R568			RK73GB2A473J	CHIP R 47K J 1/10W	
R414			RK73GB2A000J	CHIP R 0 J 1/10W		R569			RK73GB2A103J	CHIP R 10K J 1/10W	
R417,418			RK73GB2A101J	CHIP R 100 J 1/10W		R571			RK73GB2A102J	CHIP R 1.0K J 1/10W	K3
R419			RK73GB2A220J	CHIP R 22 J 1/10W		R571			RK73GB2A222J	CHIP R 2.2K J 1/10W	K2,M
R420,421			RK73GB2A221J	CHIP R 220 J 1/10W		R572			RK73GB2A000J	CHIP R 0 J 1/10W	
R422			RK73GB2A220J	CHIP R 22 J 1/10W		R573			RK73GB2A104J	CHIP R 100K J 1/10W	
R423			RK73GB2A100J	CHIP R 10 J 1/10W		R574			RK73GB2A473J	CHIP R 47K J 1/10W	
R424-426			RK73GB2A000J	CHIP R 0 J 1/10W		R575			RK73GB2A103J	CHIP R 10K J 1/10W	
R427			RK73GB2A472J	CHIP R 4.7K J 1/10W		R576			RK73GB2A473J	CHIP R 47K J 1/10W	
R428			RK73GB2A101J	CHIP R 100 J 1/10W		R577			RK73GB2A153J	CHIP R 15K J 1/10W	
R429			RK73GB2A472J	CHIP R 4.7K J 1/10W		R579			RK73GB2A000J	CHIP R 0 J 1/10W	
R502			RK73GB2A184J	CHIP R 180K J 1/10W		R580			RK73GB2A103J	CHIP R 10K J 1/10W	
R503			RK73GB2A223J	CHIP R 22K J 1/10W		R582			RK73GB2A000J	CHIP R 0 J 1/10W	
R504			RK73GB2A184J	CHIP R 180K J 1/10W		R584			RK73GB2A000J	CHIP R 0 J 1/10W	
R505			RK73GB2A102J	CHIP R 1.0K J 1/10W		R585,586			RK73GB2A473J	CHIP R 47K J 1/10W	
R506			RK73GB2A000J	CHIP R 0 J 1/10W		R587			RK73GB2A000J	CHIP R 0 J 1/10W	
R507,508			RK73GB2A154J	CHIP R 150K J 1/10W		R588			RK73GB2A473J	CHIP R 47K J 1/10W	
R512			RK73GB2A122J	CHIP R 1.2K J 1/10W		R612			RK73GB2A224J	CHIP R 220K J 1/10W	K3
R513			RK73GB2A000J	CHIP R 0 J 1/10W		R612			RK73GB2A274J	CHIP R 270K J 1/10W	K2,M
R515			RN73GH1J913D	CHIP R 91K D 1/16W		R614			RK73GB2A000J	CHIP R 0 J 1/10W	
R516			RK73GB2A102J	CHIP R 1.0K J 1/10W		R616			RK73GB2A473J	CHIP R 47K J 1/10W	

K2: TK-980(K) M: TK-980(M) K3: TK-981(K)

PARTS LIST

TX-RX UNIT (X57-6520-XX)

Ref. No.	Address	New parts	Parts No.	Description	Desti-nation	Ref. No.	Address	New parts	Parts No.	Description	Desti-nation
R624			RK73GB2A000J	CHIP R 0 J 1/10W	K2,M	D518			UDZW9.1(B)	ZENER DIODE	
R624			RK73GB2A471J	CHIP R 470 J 1/10W	K3	D520			DA2S101	DIODE	
R633			RK73GB2A000J	CHIP R 0 J 1/10W		IC1			TA75W01FUF	MOS-IC	
R645			RK73GB2A182J	CHIP R 1.8K J 1/10W	K2,M	IC2			TC75W51FUF	MOS-IC	
R658			RK73GB2A472J	CHIP R 4.7K J 1/10W		IC3			TA75W558FU-F	MOS-IC	
R667,668			RK73GB2A181J	CHIP R 180 J 1/10W		IC4	*		TC4S66F-F	MOS-IC	
R670			RK73GB2A473J	CHIP R 47K J 1/10W		IC5			M62363FP-F	MOS-IC	
R672,673			RK73GB2A473J	CHIP R 47K J 1/10W		IC6			TA75W558FU-F	MOS-IC	
R674			RK73FB2B222J	CHIP R 2.2K J 1/8W		IC7 ,8			BU4094BCFV	MOS-IC	
R675			RK73GB2A472J	CHIP R 4.7K J 1/10W		IC9			TA78L05FF	MOS-IC	
R676			RK73GB2A103J	CHIP R 10K J 1/10W		IC10			LA4422-E	BI-POLAR IC	
R677			RK73GB2A223J	CHIP R 22K J 1/10W		IC11			TA31136FNG	MOS-IC	
R678			RK73GB2A103J	CHIP R 10K J 1/10W		IC12			TA78L05FF	MOS-IC	
R679			RK73FB2B390J	CHIP R 39 J 1/8W		IC13			NJM2904E-ZB	ANALOGUE IC	
R680			RK73FB2B222J	CHIP R 2.2K J 1/8W		IC14			KIA7808API	MOS-IC	
R681			RK73GB2A223J	CHIP R 22K J 1/10W		IC15			TC4013BF(N)-F	MOS-IC	
R682			RK73GB2A473J	CHIP R 47K J 1/10W		IC16			NJM78L08UA-ZB	BI-POLAR IC	
R683			RK73GB2A103J	CHIP R 10K J 1/10W		IC17			TC75S51FE(F)	MOS-IC	
R684			RK73GB2A000J	CHIP R 0 J 1/10W	K3	IC400	2C	*	RA20H8087M101	MOS-IC	K2,M
R701			RK73GB2A102J	CHIP R 1.0K J 1/10W		IC400	2C	*	RA20H8994M101	MOS-IC	K3
R702			RK73GB2A101J	CHIP R 100 J 1/10W		IC450			LMX2352TMX/NP	ANALOGUE IC	
R705,706			RK73GB2A473J	CHIP R 47K J 1/10W		IC501			TA75W558FU-F	MOS-IC	
R716			RK73GB2A472J	CHIP R 4.7K J 1/10W		IC502			TC75W51FUF	MOS-IC	
R718			RK73GB2A154J	CHIP R 150K J 1/10W		IC503			TA75W558FU-F	MOS-IC	
R719			RK73GB2A103J	CHIP R 10K J 1/10W		IC504			TC35453FG6	MOS-IC	
R720			RK73GB2A683J	CHIP R 68K J 1/10W		IC506			BU4066BCFV	MOS-IC	
R721			RK73GB2A334J	CHIP R 330K J 1/10W		IC507			LC73872M	MOS-IC	
R722			RK73FB2B680J	CHIP R 68 J 1/8W		IC508			BU4094BCFV	MOS-IC	
R723			RK73GB2A000J	CHIP R 0 J 1/10W		IC509	*		R3111H421C-FE	MOS-IC	
R724			RK73GB2A392J	CHIP R 3.9K J 1/10W		IC510			AT29C02090TU	ROM IC	
R725			RK73GB2A562J	CHIP R 5.6K J 1/10W		IC511			30622MEP599GU	MICROCONTROLLER IC	
R726,727			RK73GB2A000J	CHIP R 0 J 1/10W		IC512			AT24C08BN-SH	ROM IC	
R733			RK73GB2A223J	CHIP R 22K J 1/10W		IC513			TA78L05FF	MOS-IC	
D1 -6				DA204U DIODE		IC711			TA75S01F-F	MOS-IC	
D7			UDZW20(B)	ZENER DIODE		Q1			2SK1824-A	FET	
D11	*		DA3J103E	DIODE		Q2			2SC2412K(S)	TRANSISTOR	
D16			1SS355	DIODE		Q4			DTD114EK	DIGITAL TRANSISTOR	
D17			DA204U	DIODE		Q5 ,6			LTC014EEBFS8	TRANSISTOR	
D18 ,19				HVC131 DIODE		Q7			2SC4226-A(R24)	TRANSISTOR	
D20			1SS355	DIODE		Q8			KRC401-P	DIGITAL TRANSISTOR	
D21			UDZW5.6(B)	ZENER DIODE		Q9			LTA014YUBFS8	TRANSISTOR	
D24			MINISMDC07502F	VARIATOR		Q10			LTC014EEBFS8	TRANSISTOR	
D26			1SS355	DIODE		Q11			KTA1298-P(Y)	TRANSISTOR	
D28			UDZW15(B)	ZENER DIODE		Q12			2SB798AZ(DLDK)	TRANSISTOR	
D31			1SS355	DIODE		Q13			LTC014EEBFS8	TRANSISTOR	
D32			22ZR-10D	SURGE ABSORBER		Q15			2SC2059K(P)	TRANSISTOR	
D34			UDZW18(B)	ZENER DIODE		Q17			2SC4116(GR)F	TRANSISTOR	
D37			DSA3A1	DIODE		Q18			2SK1824-A	FET	
D38			UDZW5.1(B)	ZENER DIODE		Q19			2SB1565(E,F)	TRANSISTOR	
D200			HSM88AS-E	DIODE		Q20			LTA044EUBFS8	TRANSISTOR	
D208-210			L709CER-T	DIODE		Q21			LTC044EUBFS8	TRANSISTOR	
D401			KDS120E-P	DIODE		Q22			LTC014EEBFS8	TRANSISTOR	
D501			DA204U	DIODE		Q25 ,26			LTA014EEBFS8	TRANSISTOR	
D502			MINISMDC07502F	VARIATOR		Q27			2SA1641(S,T)	TRANSISTOR	
D503-505			DA204U	DIODE		Q28			LTC014EEBFS8	TRANSISTOR	
D507	*		DA3J103E	DIODE		Q30			LTA014EEBFS8	TRANSISTOR	
D508,509			MA3J742	DIODE		Q31			LTC014EEBFS8	TRANSISTOR	
D510			HSC119	DIODE		Q32			2SK1824-A	FET	
						Q33			LTC044EEBFS8	TRANSISTOR	

K2: TK-980(K) M: TK-980(M) K3: TK-981(K)

PARTS LIST

TX-RX UNIT (X57-6520-XX)
PLL/VCO UNIT (X58-4530-XX)

Ref. No.	Address	New parts	Parts No.	Description	Destination	Ref. No.	Address	New parts	Parts No.	Description	Destination
Q34		*	2SC2712-F(GR)	TRANSISTOR		L103			L34-4518-05	AIR-CORE COIL	
Q201			2SC4094(R37)	TRANSISTOR		L104			L41-1098-40	SMALL FIXED INDUCTOR(1000NH)	
Q202			2SC3356-A(R24)	TRANSISTOR		L105			L41-1875-47	SMALL FIXED INDUCTOR(18NH)	K3
Q203			3SK255-A	FET		L105	*		L41-3975-47	SMALL FIXED INDUCTOR(39NH)	K2,M
Q204			2SK2596-E	FET		L106	*		L41-1575-47	SMALL FIXED INDUCTOR(15NH)	K3
Q205			LTC044EEBFS8	TRANSISTOR		L106	*		L41-2775-47	SMALL FIXED INDUCTOR(27NH)	K2,M
Q300			2SC4226-A(R24)	TRANSISTOR		L107			L41-1595-33	SMALL FIXED INDUCTOR(1.5UH)	
Q301,302			2SC3722K(S)	TRANSISTOR		R100,101			RK73GB2A000J	CHIP R 0 J 1/10W	
Q400			KTA2014E-P(GR)	TRANSISTOR		R102			RK73GB2A102J	CHIP R 1.0K J 1/10W	
Q501			DTC314TU	DIGITAL TRANSISTOR		R103			RK73GB2A000J	CHIP R 0 J 1/10W	
Q502			LTC044EEBFS8	TRANSISTOR		R104			RK73GB2A101J	CHIP R 100 J 1/10W	
Q503			2SC4617(S)	TRANSISTOR		R105			RK73GB2A823J	CHIP R 82K J 1/10W	
Q507			LTC044EEBFS8	TRANSISTOR		R106			RK73GB2A154J	CHIP R 150K J 1/10W	
Q508,509			2SC4617(S)	TRANSISTOR		R107	*		RN73GH1J270D	CHIP R 27 D 1/16W	
Q510			2SC4725	TRANSISTOR	K2,M	R108,109			RK73GB2A101J	CHIP R 100 J 1/10W	
Q511			DTA144WE	DIGITAL TRANSISTOR		R110			RN73GH1J221D	CHIP R 220 D 1/16W	
Q512			LTC014EEBFS8	TRANSISTOR		R111			RK73GB2A223J	CHIP R 22K J 1/10W	
Q513			2SC2873(Y)F	TRANSISTOR		R112			RK73GB2A103J	CHIP R 10K J 1/10W	
Q515			LTC014EEBFS8	TRANSISTOR		R113			RK73GB2A470J	CHIP R 47 J 1/10W	
TH1			157-104-55001	THERMISTOR		R114			RK73GB2A000J	CHIP R 0 J 1/10W	
A1			X58-4530-10	SUB UNIT	K2,M	D100,101			1SV283F	VARIABLE CAPACITANCE DIODE	
A1			X58-4530-11	SUB UNIT	K3	D102			1SV214-F	VARIABLE CAPACITANCE DIODE	
PLL/VCO UNIT (X58-4530-XX) -10:TK-980 -11:TK-981						Q100			2SC4226-A(R24)	TRANSISTOR	
C100			CK73GB1H471K	CHIP C 470PF K		Q101			2SK508NV(K52)	FET	
C101			CC73GCH1H080B	CHIP C 8.0PF B	K2,M	Q102			2SC4226-A(R24)	TRANSISTOR	
C101			CC73GCH1H4R5B	CHIP C 4.5PF B	K3						
C102			CC73GCH1HR75B	CHIP C 0.75PF B							
C103			CK73GB1H471K	CHIP C 470PF K							
C104			CC73GCH1H010B	CHIP C 1.0PF B	K3						
C104			CC73GCH1H1R5B	CHIP C 1.5PF B	K2,M						
C105			CC73GCH1H040B	CHIP C 4.0PF B	K3						
C105			CC73GCH1H060B	CHIP C 6.0PF B	K2,M						
C106			CC73GCH1HR75B	CHIP C 0.75PF B	K2,M						
C106,107			CC73GCH1HR75B	CHIP C 0.75PF B	K3						
C107			CC73GCH1H0R5B	CHIP C 0.5PF B	K2,M						
C108			CK73GB1H102K	CHIP C 1000PF K							
C109			CC73GCH1H030B	CHIP C 3.0PF B							
C110			CC73GCH1H050B	CHIP C 5.0PF B							
C111			CC73GCH1H470J	CHIP C 47PF J							
C112			CK73GB1H471K	CHIP C 470PF K							
C113			CC73GCH1H040B	CHIP C 4.0PF B	K2,M						
C113			CC73GCH1H050B	CHIP C 5.0PF B	K3						
C114			CK73GB1H102K	CHIP C 1000PF K	K2,M						
C114			CK73GB1H471K	CHIP C 470PF K	K3						
C115			CC73GCH1H030B	CHIP C 3.0PF B							
C116			CC73GCH1H060B	CHIP C 6.0PF B							
C117			CK73GB1H102K	CHIP C 1000PF K							
C118			CC73GCH1HR75B	CHIP C 0.75PF B							
TC100			C05-0384-05	CERAMIC TRIMMER CAPACITOR(10P)							
CN100			E40-5699-05	PIN ASSY(7P)							
-			F10-2279-04	SHIELDING CASE							
-		*	F12-0492-04	SHIELDING SHEET	K3						
L100,101			L41-1595-33	SMALL FIXED INDUCTOR(1.5UH)							
L102		*	L41-1075-47	SMALL FIXED INDUCTOR(10NH)	K3						
L102		*	L41-1275-47	SMALL FIXED INDUCTOR(12NH)	K2,M						

K2: TK-980(K) M: TK-980(M) K3: TK-981(K)

EXPLODED VIEW

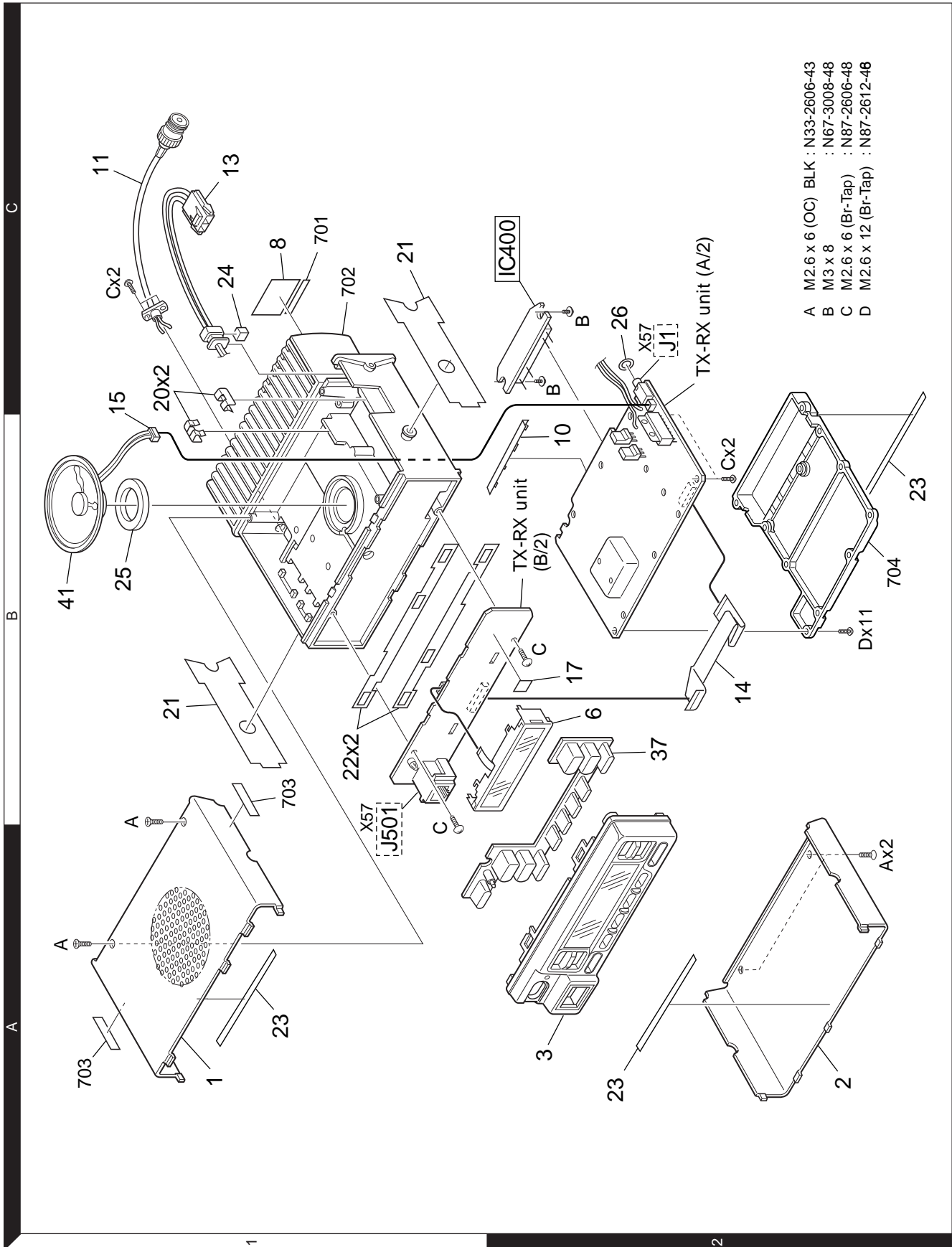

Parts with the exploded numbers larger than 700 are not supplied.

If a part reference number is listed in a box on the exploded view of the PCB, that part does not come with the PCB.

These parts must be ordered separately.

PC BOARD TK-980/981

PLL/VCO (X58-4530-XX) -10 : TK-980 -11 : TK-981
 Component side view (J79-0285-09)

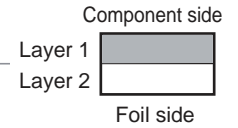
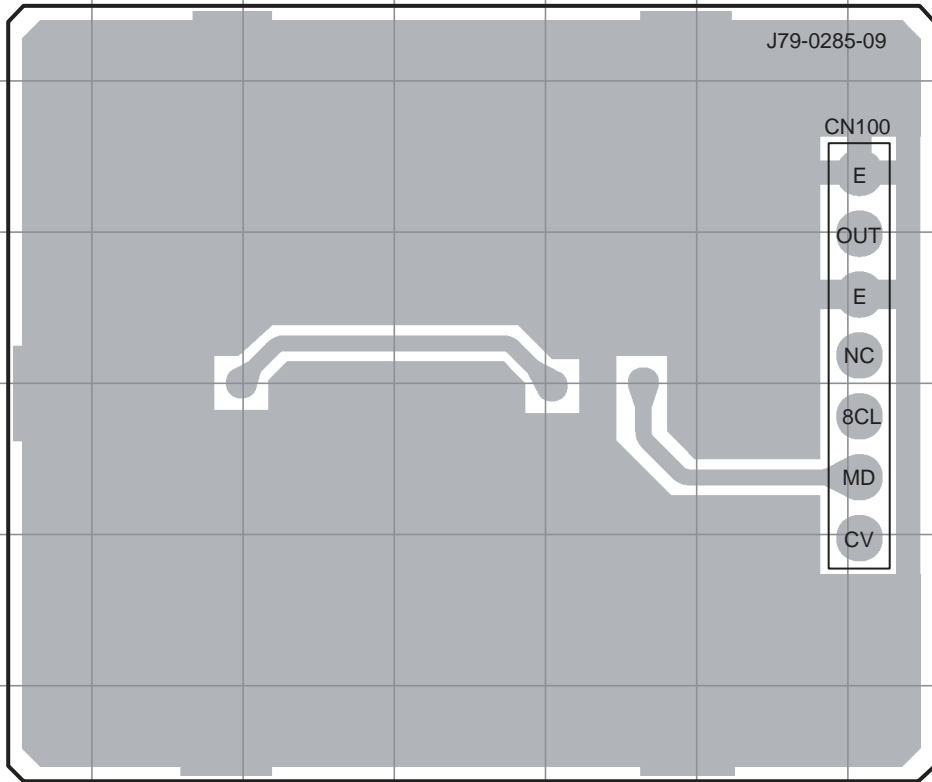

PLL/VCO (X58-4530-XX) -10 : TK-980 -11 : TK-981
 Foil side view (J79-0285-09)

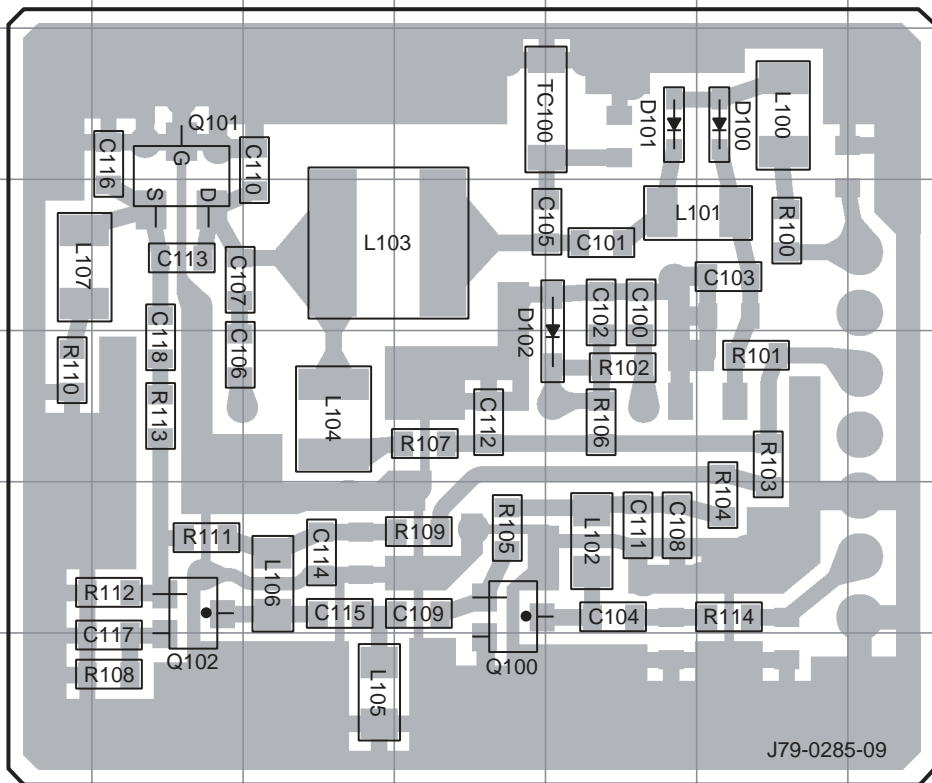

Ref. No.	Address
Q100	12E
Q101	9C
Q102	12C
D100	9G
D101	9F
D102	11F

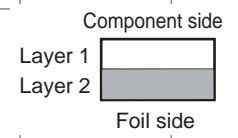

PC BOARD TK-980/981

TX-RX UNIT : TX-RX SECTION (X57-6520-XX) (A/2)
-12 : TK-980 -13 : TK-981
Component side view (J79-0294-09 A/2)

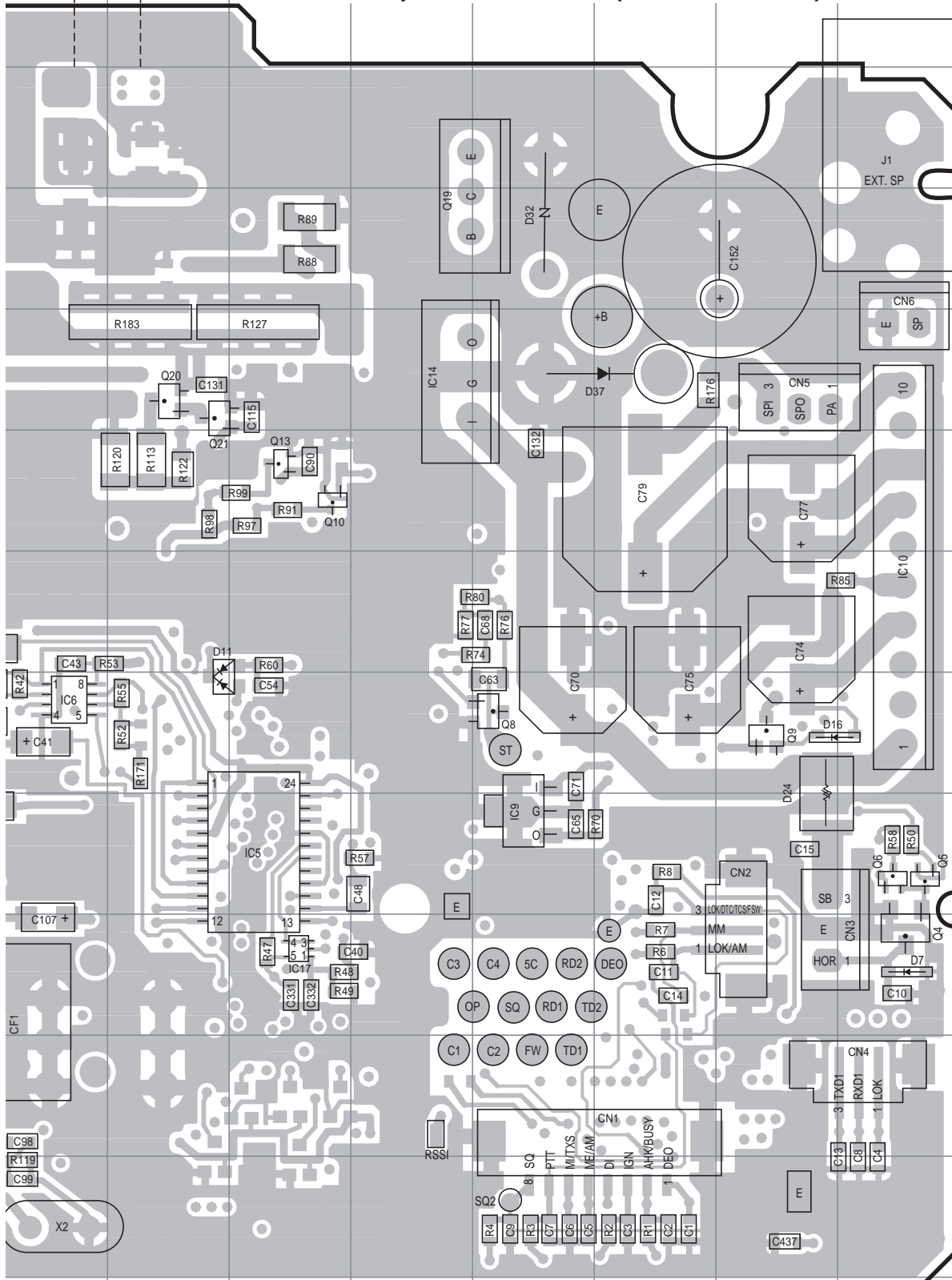

Ref. No.	Address
IC5	10L
IC6	9J
IC9	10N
IC10	8Q
IC11	12I
IC14	6M
IC17	11L
IC450	10G
Q4	11Q
Q5	10Q
Q6	10Q
Q8	9N
Q9	9P
Q10	7L
Q13	7L
Q19	5N
Q20	6K
Q21	6K
Q32	11I
Q205	13B
Q300	9E
Q301	11F
Q302	11E
Q400	9F
D7	11Q
D11	9K
D16	9Q
D24	9P
D32	5N
D37	6O
D401	9F

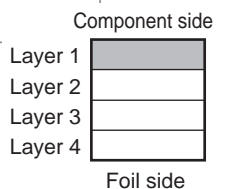

TK-980/981 PC BOARD

TX-RX UNIT : TX-RX SECTION (X57-6520-XX) (A/2)

-12 : TK-980 -13 : TK-981

Foil side view (J79-0294-09 A/2)

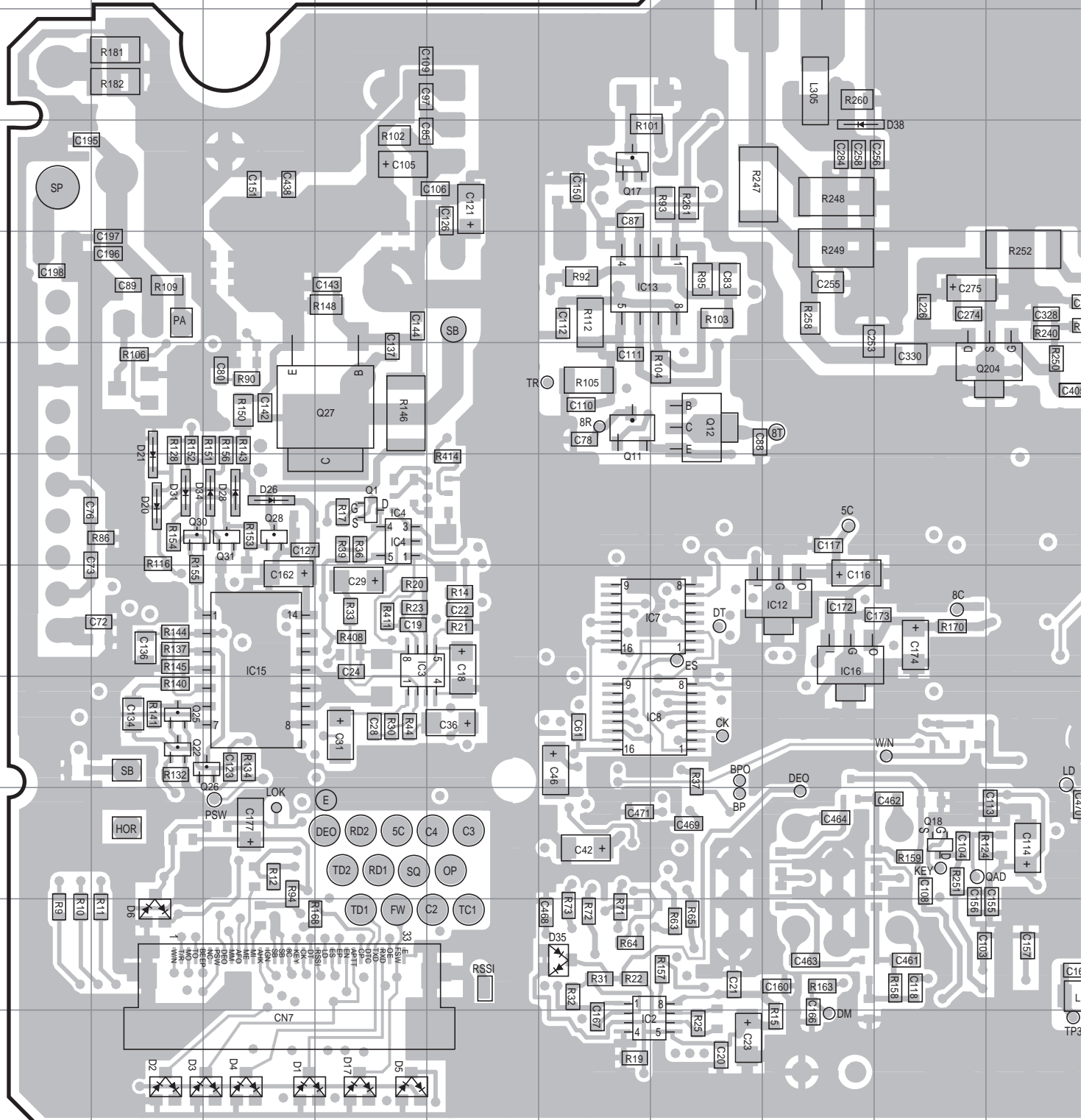

PC BOARD TK-980/981

IC400

**TX-RX UNIT : TX-RX SECTION
(X57-6520-XX) (A/2)**

-12 : TK-980 -13 : TK-981

Foil side view (J79-0294-09 A/2)

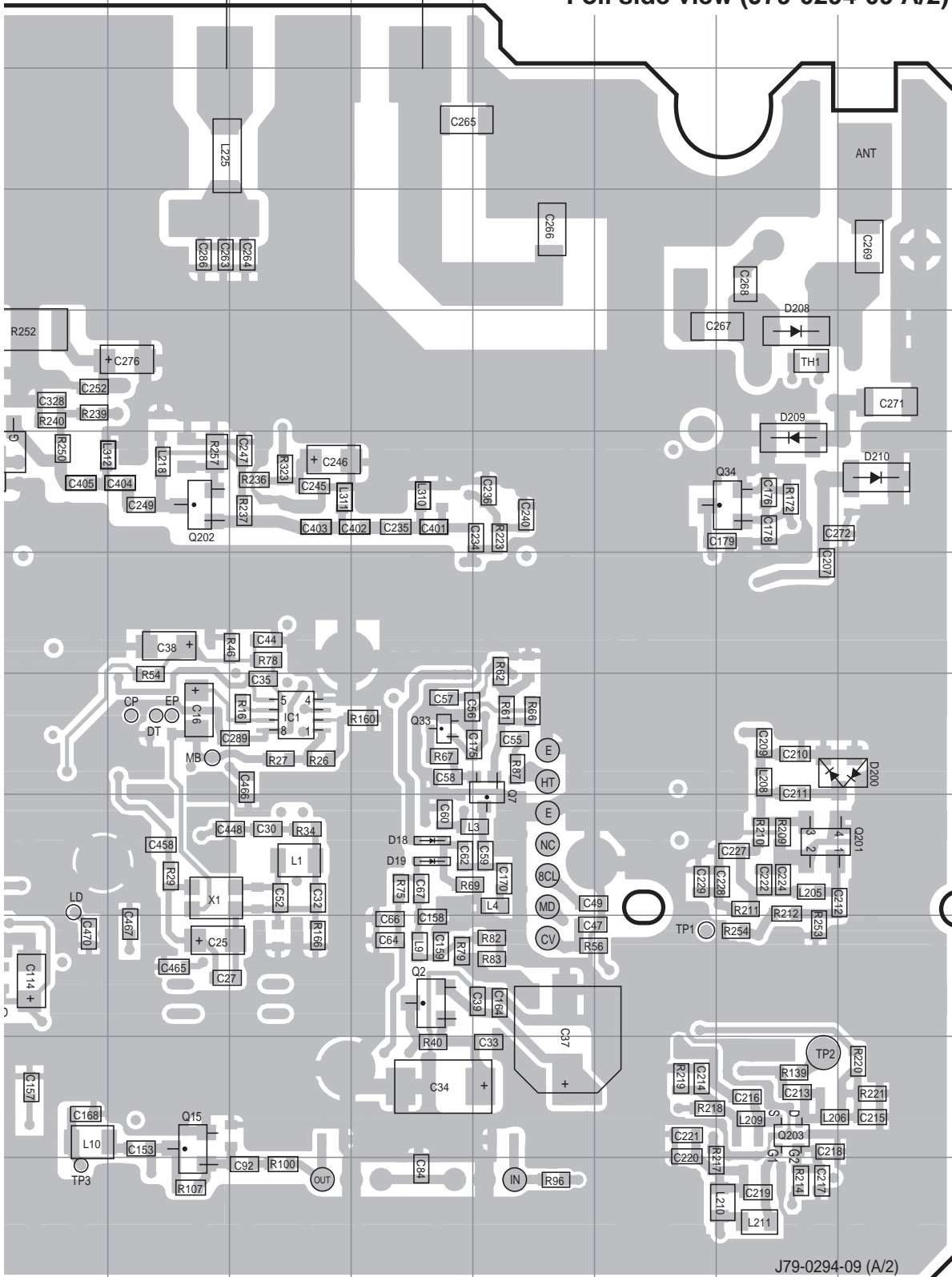

Ref. No.	Address
IC1	9L
IC2	13F
IC3	9D
IC4	8D
IC7	9G
IC8	10G
IC12	9H
IC13	6F
IC15	9C
IC16	9H
IC400	2J
Q1	8D
Q2	11M
Q7	9N
Q11	7F
Q12	7G
Q15	12K
Q17	5F
Q18	11I
Q22	10B
Q25	10B
Q26	10C
Q27	7D
Q28	8C
Q30	8B
Q31	8C
Q33	9M
Q34	7P
Q201	10P
Q202	7K
Q203	12P
Q204	7J
D1	13C
D2	13B
D3	13C
D4	13C
D5	13D
D6	12B
D17	13D
D18	10M
D19	10M
D20	8B
D21	8B
D26	8C
D28	8C
D31	8B
D34	8C
D35	12F
D38	5H
D200	9Q
D208	6P
D209	7P
D210	7Q

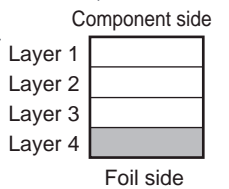

J79-0294-09 (A/2)

TK-980/981 PC BOARD

TX-RX UNIT : CONTROL SECTION (X57-6520-XX)(B/2) -12 : TK-980 -13 : TK-981

Component side view (J79-0294-09 B/2)

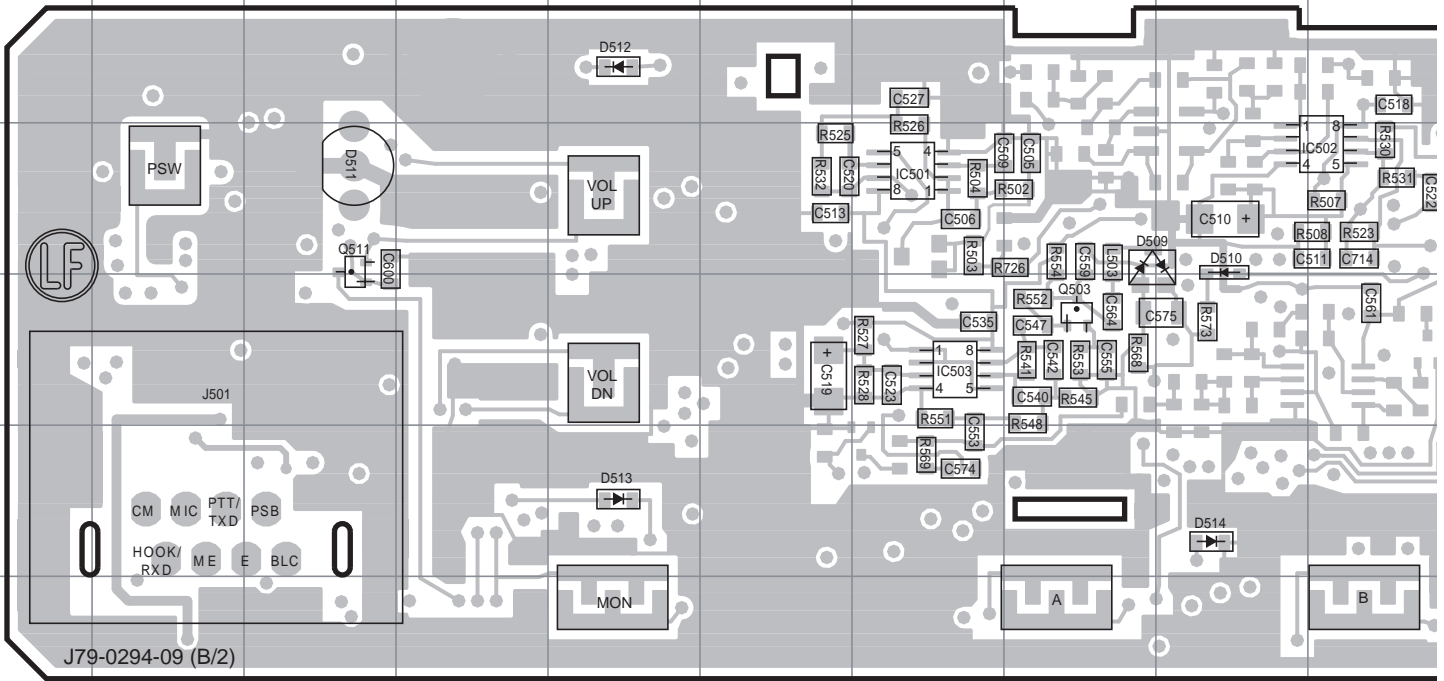

Foil side view (J79-0294-09 B/2)

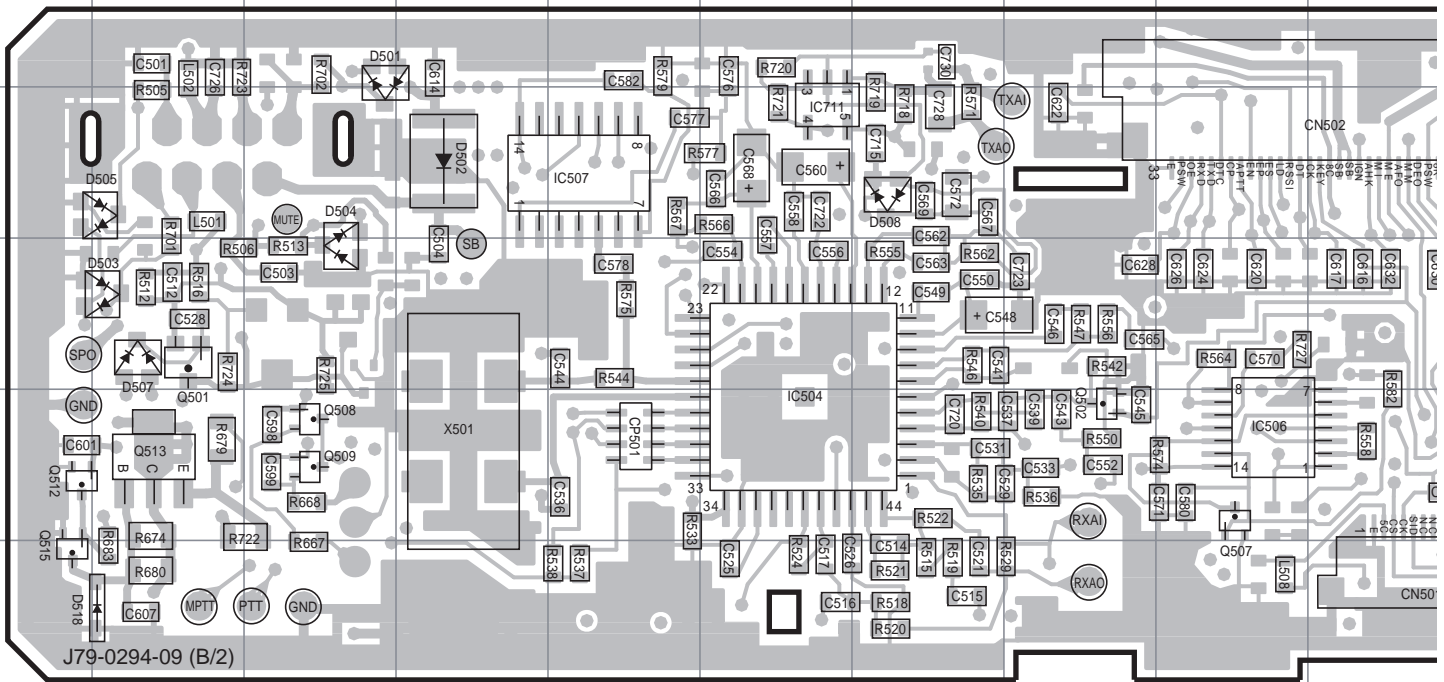

TK-980/981 SCHEMATIC DIAGRAM

TX-RX UNIT : TX-RX SECTION(X57-6520-XX) (A/2)

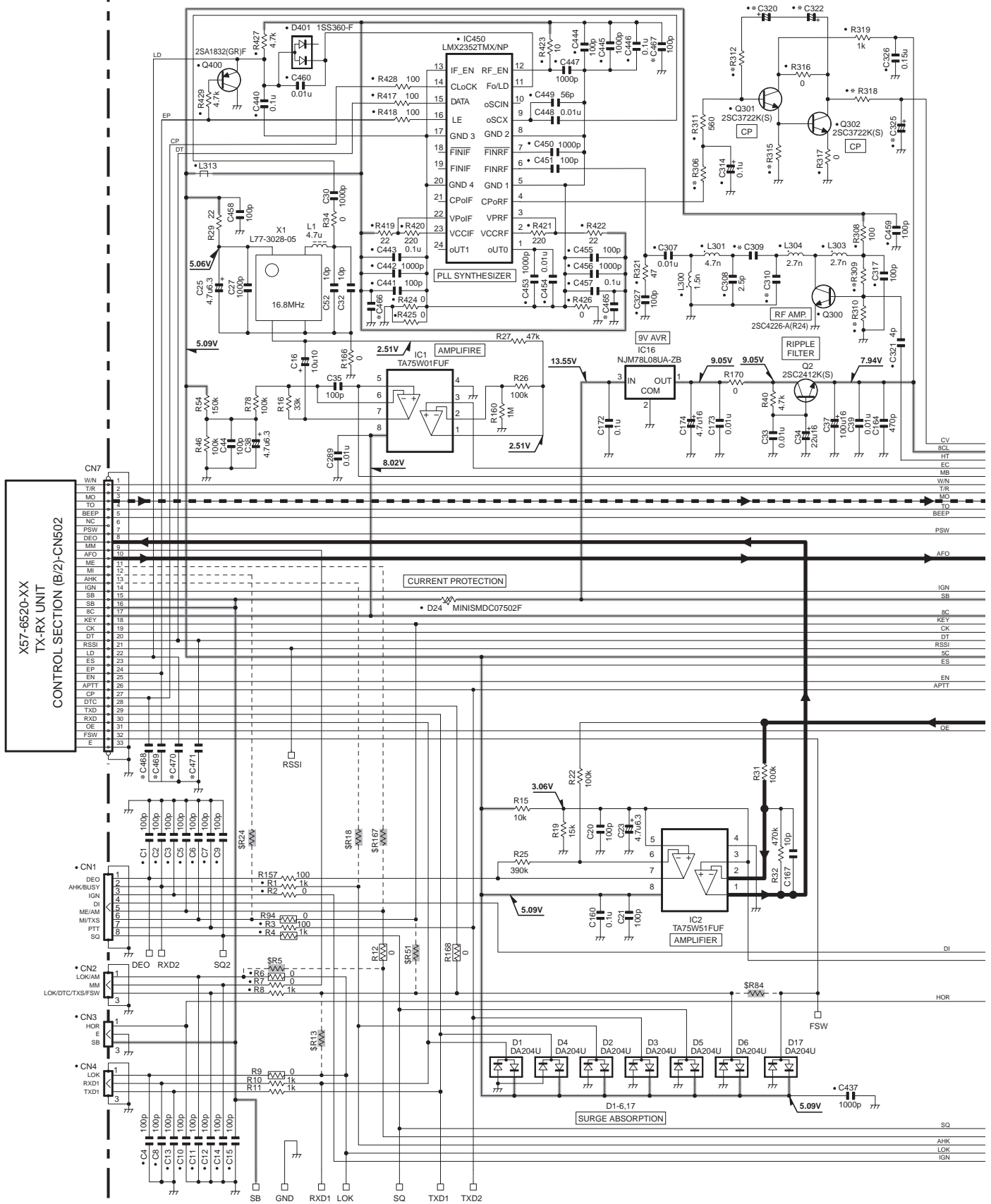

X57-6520-XX	R306	R309	R310	R312	R315	R318	C309	C310	C320	C322	C325	C465	C466	C467	C468	C469	C470	C471
-12 TK-980	1k	33k	10k	47k	47k	390	1p	2.5p	6.8u10	6.8u10	0.68u20	NO	NO	NO	NO	NO	NO	NO
-13 TK-981	1.8k	100k	47k	2.2k	10k	330	0.5p	1.5p	1u10	1u10	0.47u25	100p	100p	100p	100p	100p	100p	100p

SCHEMATIC DIAGRAM TK-980/981

TX-RX UNIT : TX-RX SECTION(X57-6520-XX) (A/2)

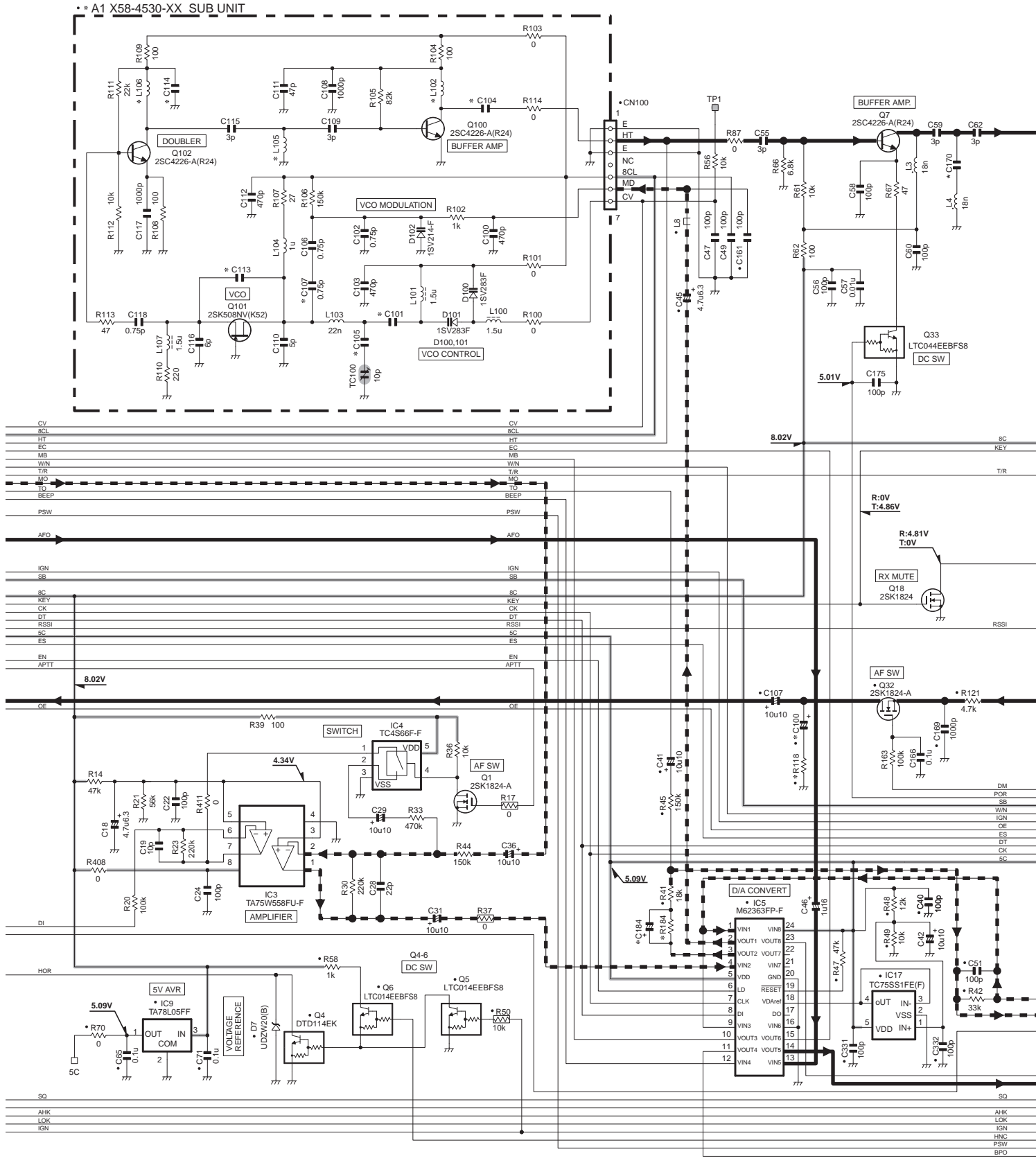

X58-4530-XX	C101	C104	C105	C107	C113	C114	L102	L105	L106
-10 TK-980	8p	1.5p	6p	0.5p	4p	1000p	12n	39n	27n
-11 TK-981	4.5p	1P	4p	0.75p	5p	470p	10n	18n	15n

X57-6520-XX (A/2)	A1	R118	R184	C100	C170	C184
-12 TK-980	X58-4530-10	3.9k	0	10u/10	7p(B)	NO
-13 TK-981	X58-4530-11	NO	NO	NO	5p	10u

TK-980/981 SCHEMATIC DIAGRAM

TX-RX UNIT : TX-RX SECTION(X57-6520-XX) (A/2)

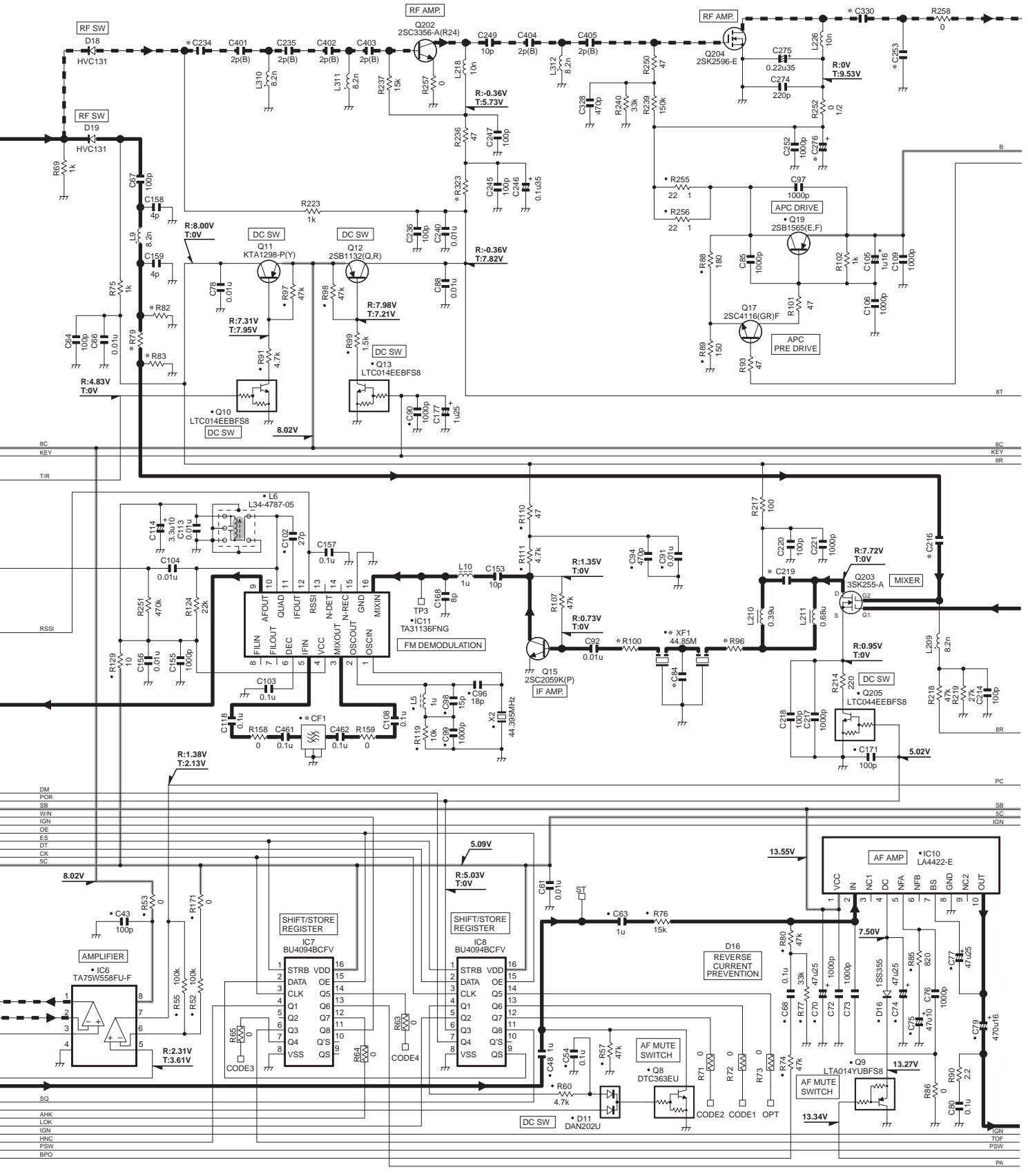

X57-6520-XX (A/2)	XF1	CF1	R79	R82	R83	R96	R100	R323	C84	C216	C219	C234	C253	C276	C330
-12 TK-980	L71-0525-05	L72-0998-05	39	150	150	330	330	47	12p	1.5p(B)	11p	15p	6p	4.7u20	15p
-13 TK-981	L71-0583-05	L72-0986-05	18	270	270	180	150	68	22p	1p(B)	12p	100p	8p	2.2u20	47p

SCHEMATIC DIAGRAM TK-980/981

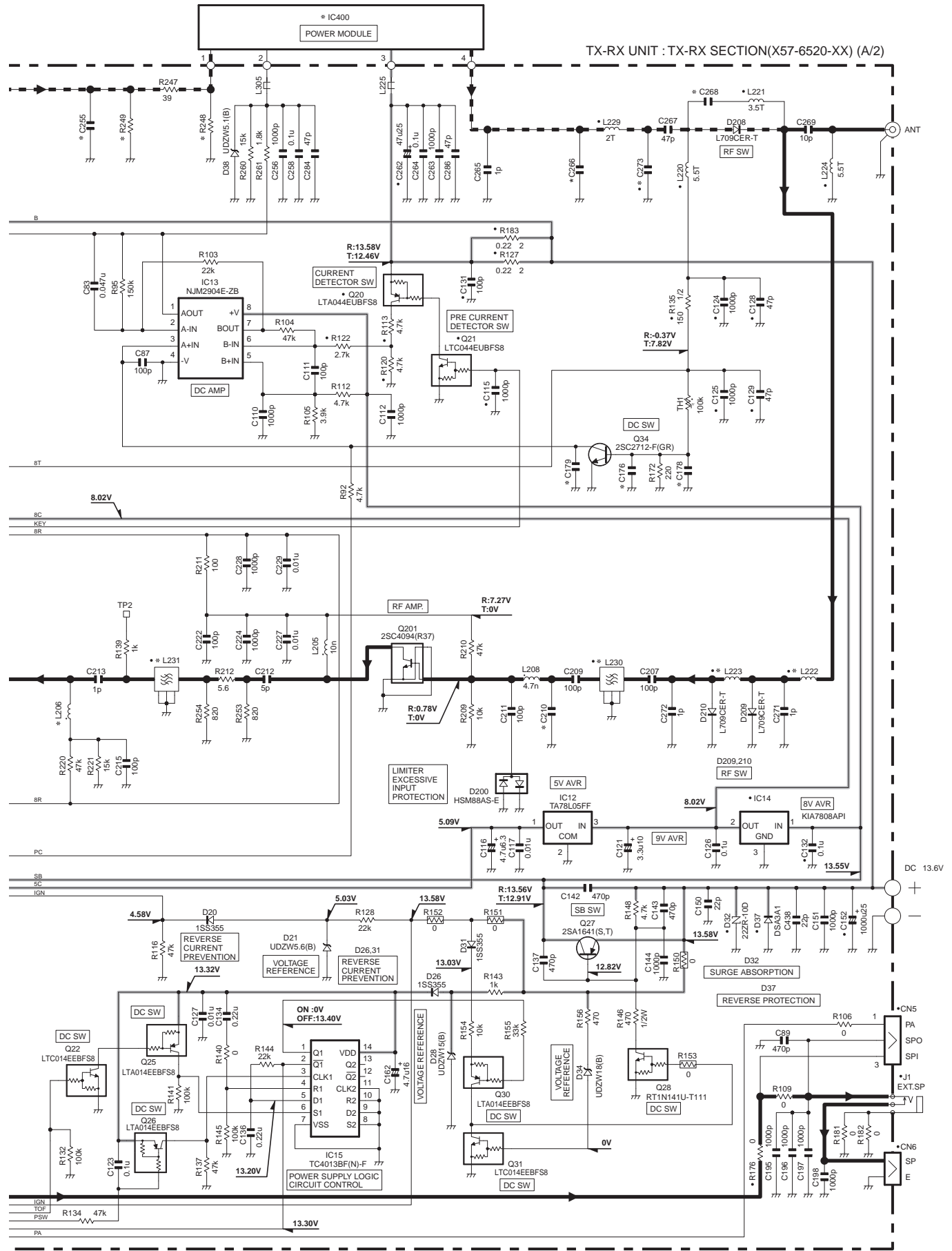

X57-6520-XX (A/2)	IC400	L206	L222	L223	L230	L231	R248	R249	C176	C178	C179	C210	C255	C266	C268	C273	
-12	TK-980	RA20H8087M	8.2n	L34-1307-05	L34-1307-05	L79-1910-05	L79-1910-05	120(1/2w)	120(1/2w)	47p	47p	NO	4p	10p	3p	47p	3p
-13	TK-981	RA20H8994M	6.8n	L34-1313-05	L34-1313-05	L79-1911-05	L79-1911-05	150(1/2w)	150(1/2w)	100p	NO	100p	3p	4p	1p	1p	2p

Note : The components marked with a dot (•) are parts of layer 1.

TK-980/981 SCHEMATIC DIAGRAM

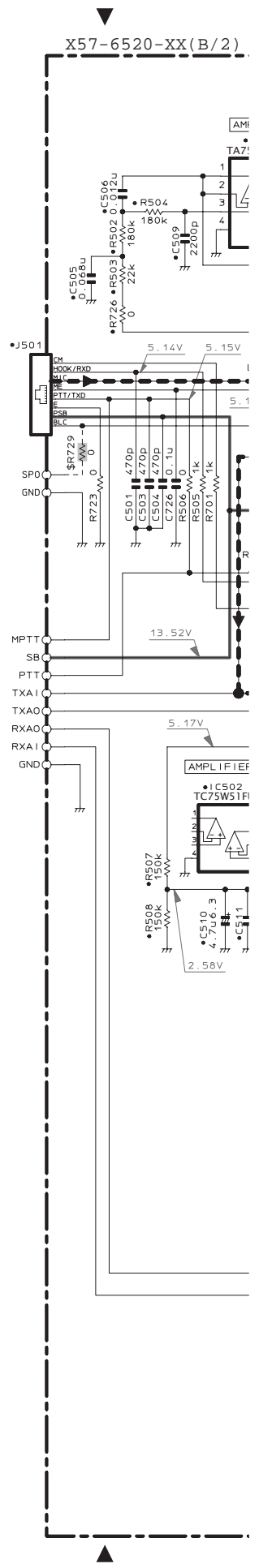

X57-6520-XX (B/2)	Q510	C593	C594	C595	C596	C597	R571	R612	R624	R645	R684
-12 TK-980	2SC4725	0.047u	18p	18p	4p	0.01u	2.2k	270k	0	1.8k	NO
-13 TK-981	NO	0.022u	15p	15p	NO	NO	1k	220k	470	NO	0

SCHEMATIC DIAGRAM TK-980/981

X57-6520-XX(B/2) TX-RX UNIT CONTROL SECTION

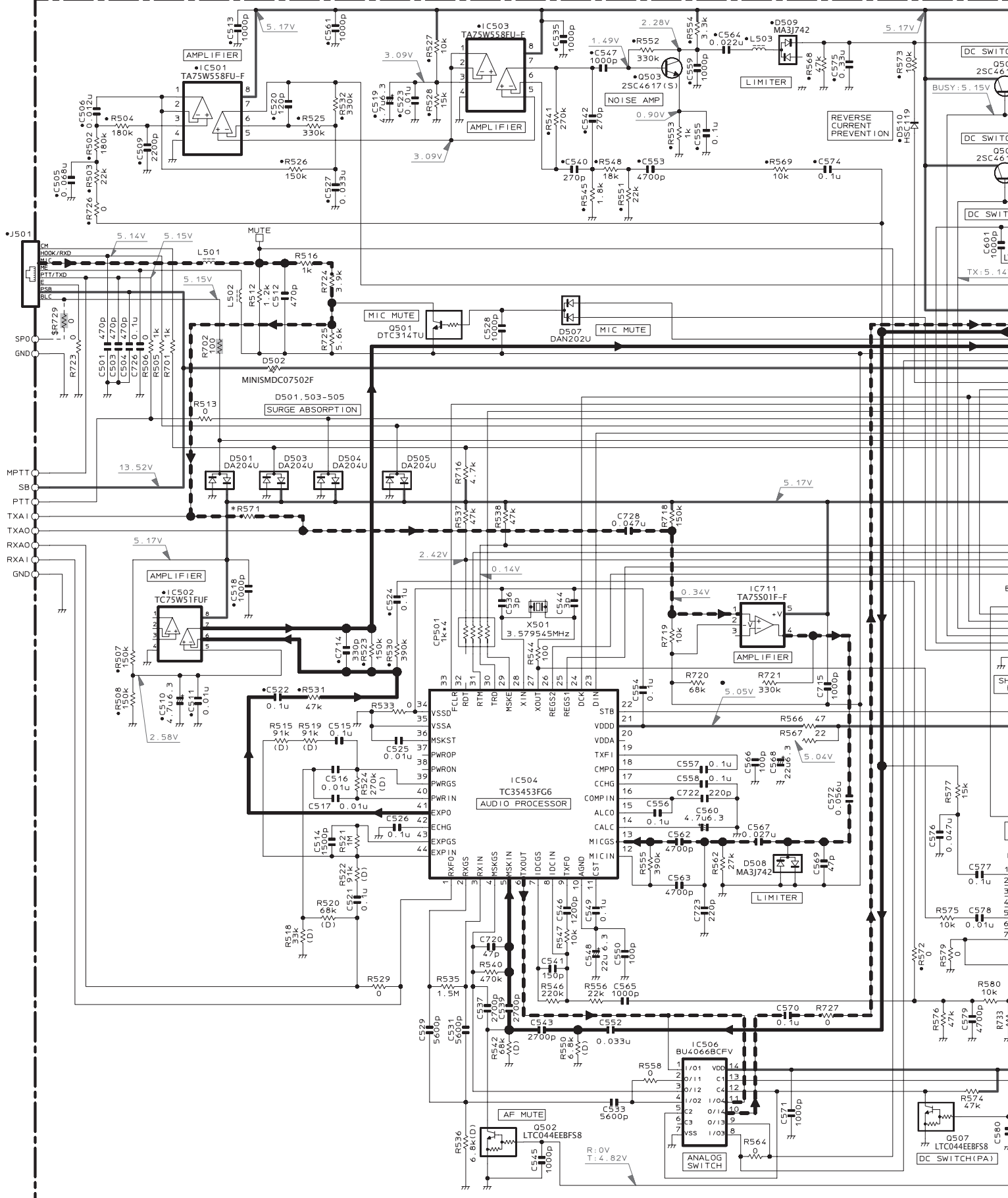

TK-980/981 SCHEMATIC DIAGRAM

TX-RX UNIT : CONTROL SECTION(X57-6520-XX) (B/2)

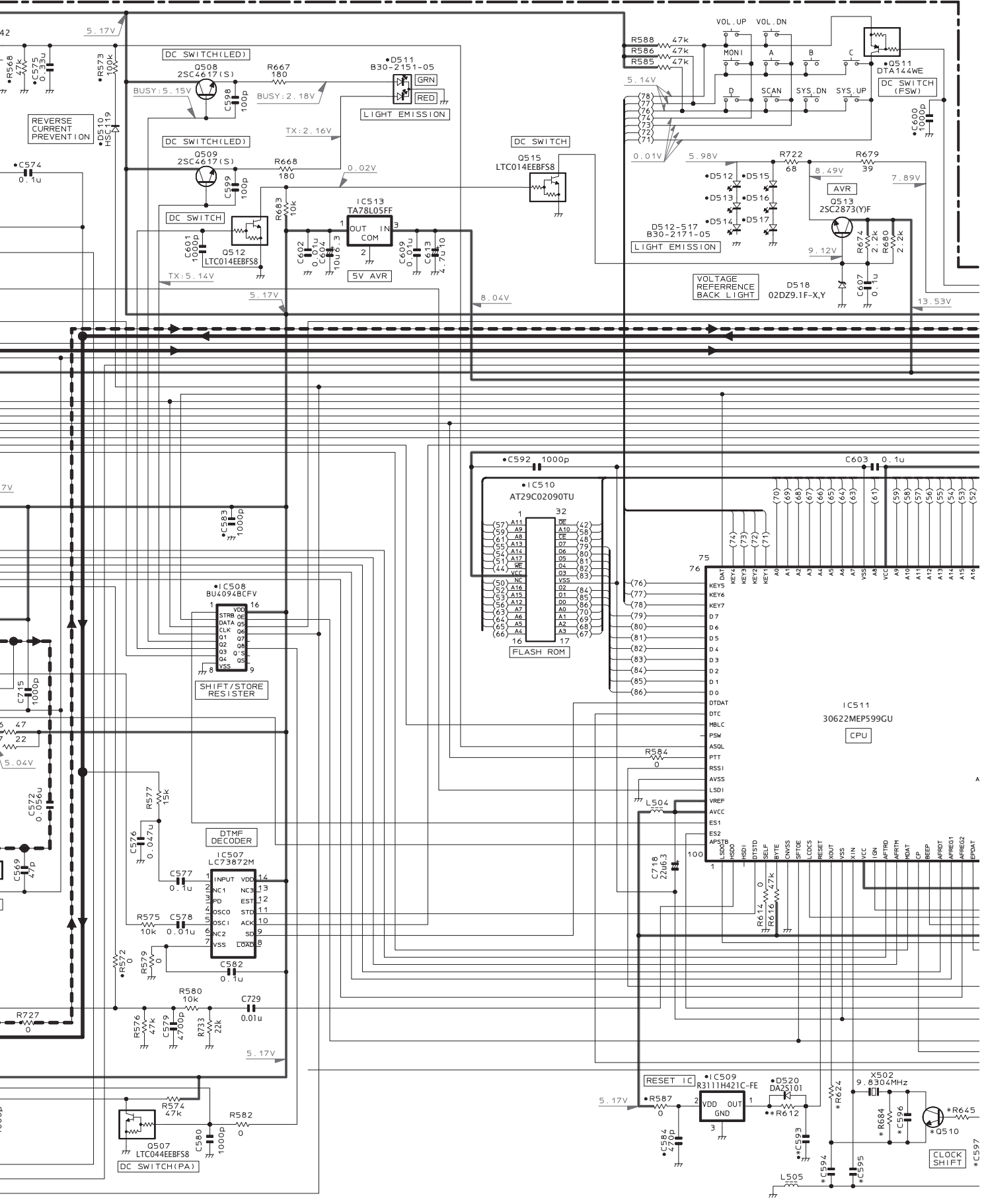

SCHEMATIC DIAGRAM TK-980/981

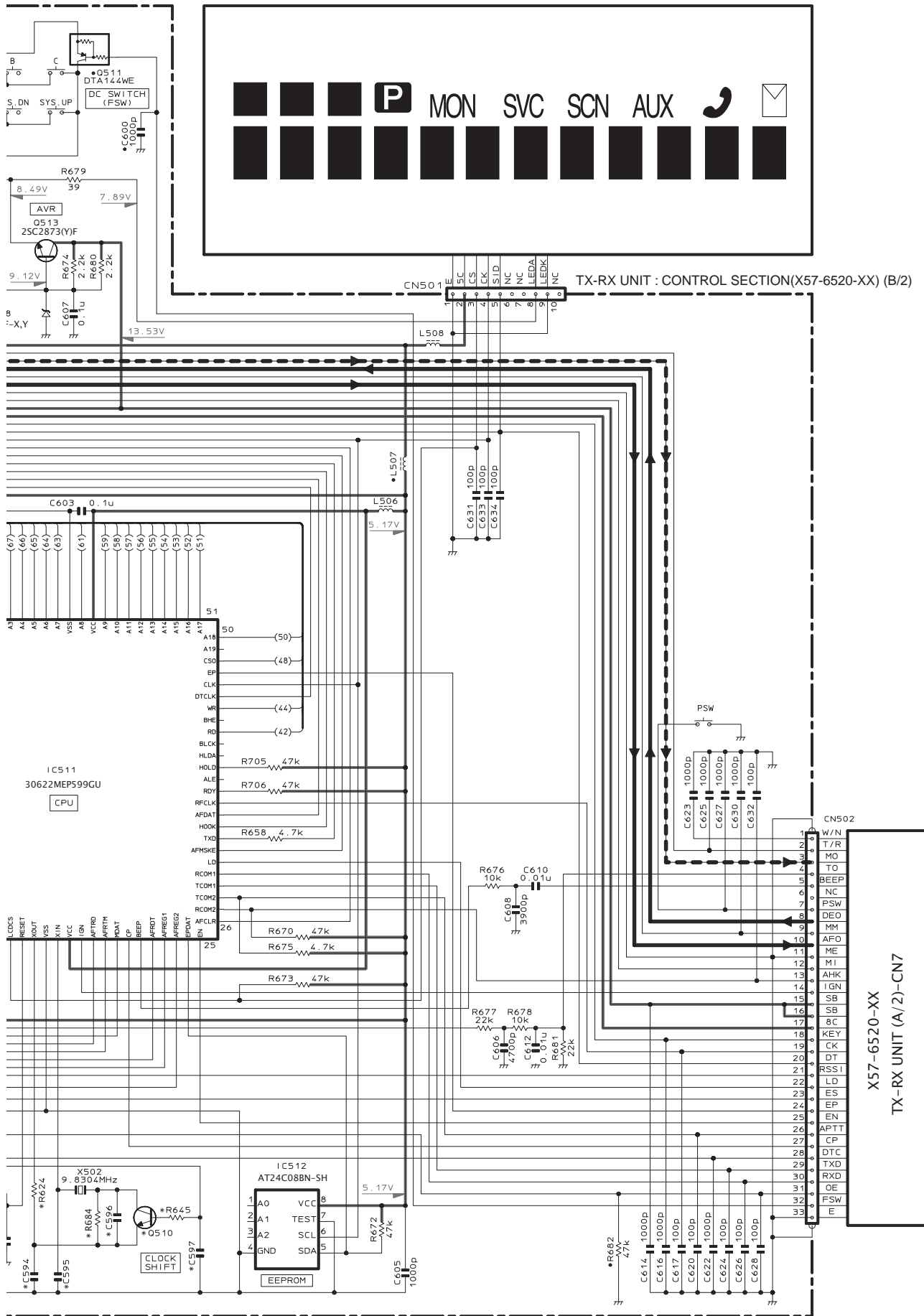

Note : The components marked with a dot (•) are parts of layer 1.

TK-980/981

JVC KENWOOD Corporation

3-12, Moriyacho, Kanagawa-ku, Yokohama-shi,
Kanagawa, 221-0022 Japan

Kenwood U.S.A. Corporation

P.O. BOX 22745, 2201 East Dominguez Street, Long Beach,
CA 90801-5745, U.S.A.

Kenwood Electronics Canada Inc.

6070 Kestrel Road, Mississauga, Ontario, Canada L5T 1S8

Kenwood Electronics Deutschland GmbH

Rembrücker Str. 15, 63150 Heusenstamm, Germany

Kenwood Electronics Belgium N.V.

Leuvensesteenweg 248 J, 1800 Vilvoorde, Belgium

Kenwood Electronics France S.A.

L'Etoile Paris Nord 2, 50 Allée des Impressionnistes,
Bp 58416 Villepinte, 95944 Roissy Ch De Gaulle Cedex

Kenwood Electronics UK Limited

Kenwood House, Dwight Road, Watford, Herts.,
WD18 9EB United Kingdom

Kenwood Electronics Europe B.V.

Amsterdamseweg 37, 1422 AC Uithoorn, The Netherlands

Kenwood Electronics Italia S.p.A.

Via G. Sirtori, 7/9 20129 Milano, Italy

Kenwood Ibérica, S.A.

Carretera de Rubi, 88 Planta 1 A 08174 Sant Cugat del Vallès
Barcelona, Spain

Kenwood Electronics Australia Pty. Ltd.

Talavera Business Park Building A, 4 Talavera Road,
North Ryde NSW 2113 Australia

Kenwood Electronics (Hong Kong) Ltd.

Suite 2504, 25/F, Tower 2, Nina Tower, No. 8 Yeung Uk Road,
Tsuen Wan, New Territories, Hong Kong

Kenwood Electronics Singapore Pte Ltd

1 Ang Mo Kio Street 63, Singapore 569110

TK-980/981 PC BOARD

PC BOARD TK-980/981

**TX-RX UNIT : TX-RX SECTION
(X57-6520-XX) (A/2)**
-12 : TK-980 -13 : TK-981
**Component side view
(J79-0294-09 A/2)**

TX-RX UNIT : TX-RX SECTION (X57-6520-XX) (A/2)
-12 : TK-980 -13 : TK-981
Component side view (J79-0294-09 A/2)

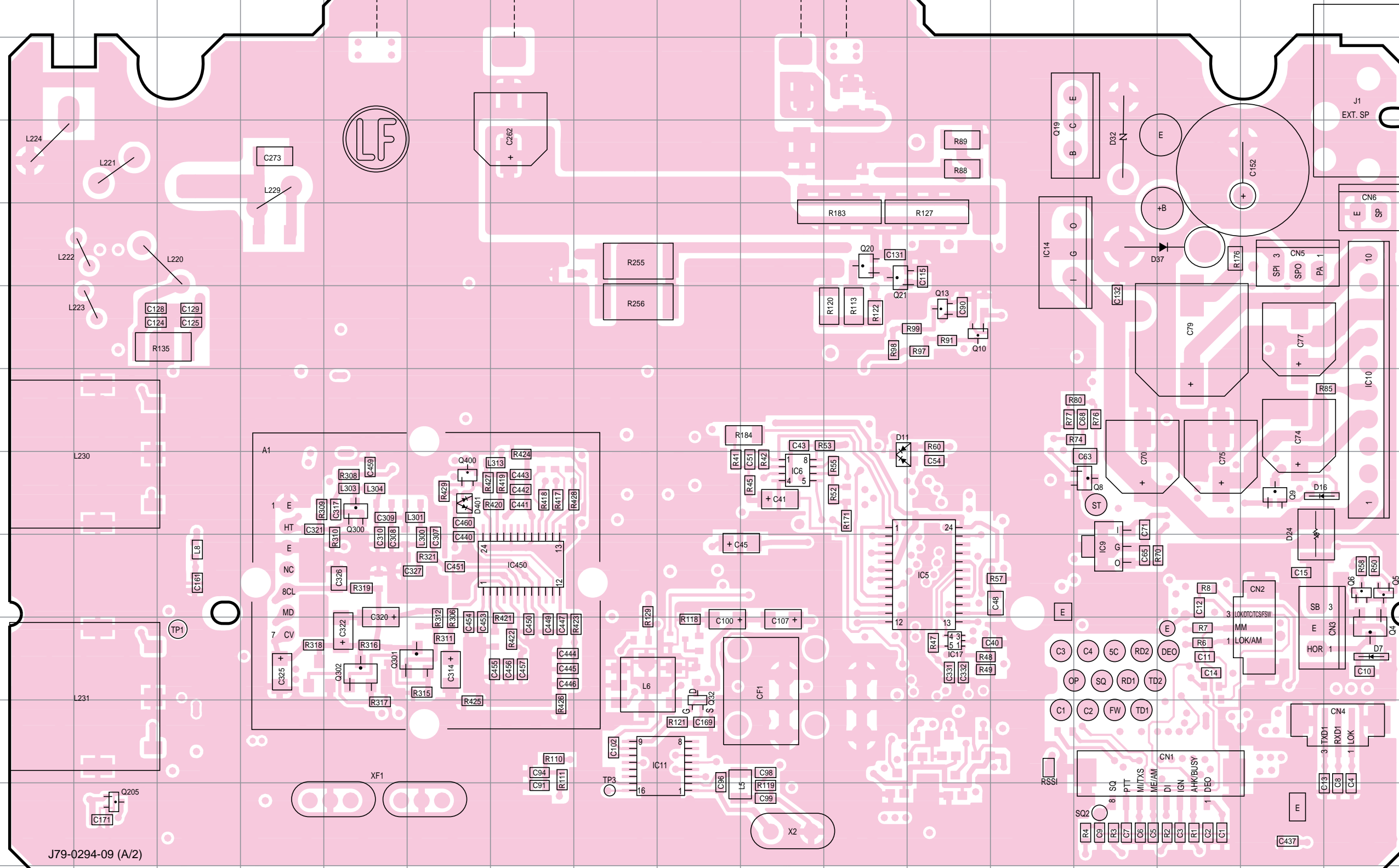

Ref. No.	Address
IC5	10L
IC6	9J
IC9	10N
IC10	8Q
IC11	12I
IC14	6M
IC17	11L
IC450	10G
Q4	11Q
Q5	10Q
Q6	10Q
Q8	9N
Q9	9P
Q10	7L
Q13	7L
Q19	5N
Q20	6K
Q21	6K
Q32	11I
Q205	13B
Q300	9E
Q301	11F
Q302	11E
Q400	9F
D7	11Q
D11	9K
D16	9Q
D24	9P
D32	5N
D37	6O
D401	9F

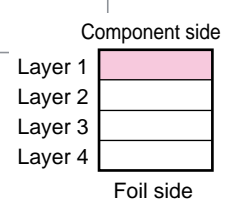

J79-0294-09 (A/2)

TK-980/981 PC BOARD

PC BOARD TK-980/981

TX-RX UNIT : TX-RX SECTION (X57-6520-XX) (A/2)

-12 : TK-980 -13 : TK-981

Foil side view (J79-0294-09 A/2)

TX-RX UNIT : TX-RX SECTION

(X57-6520-XX) (A/2)

-12 : TK-980 -13 : TK-981

Foil side view (J79-0294-09 A/2)

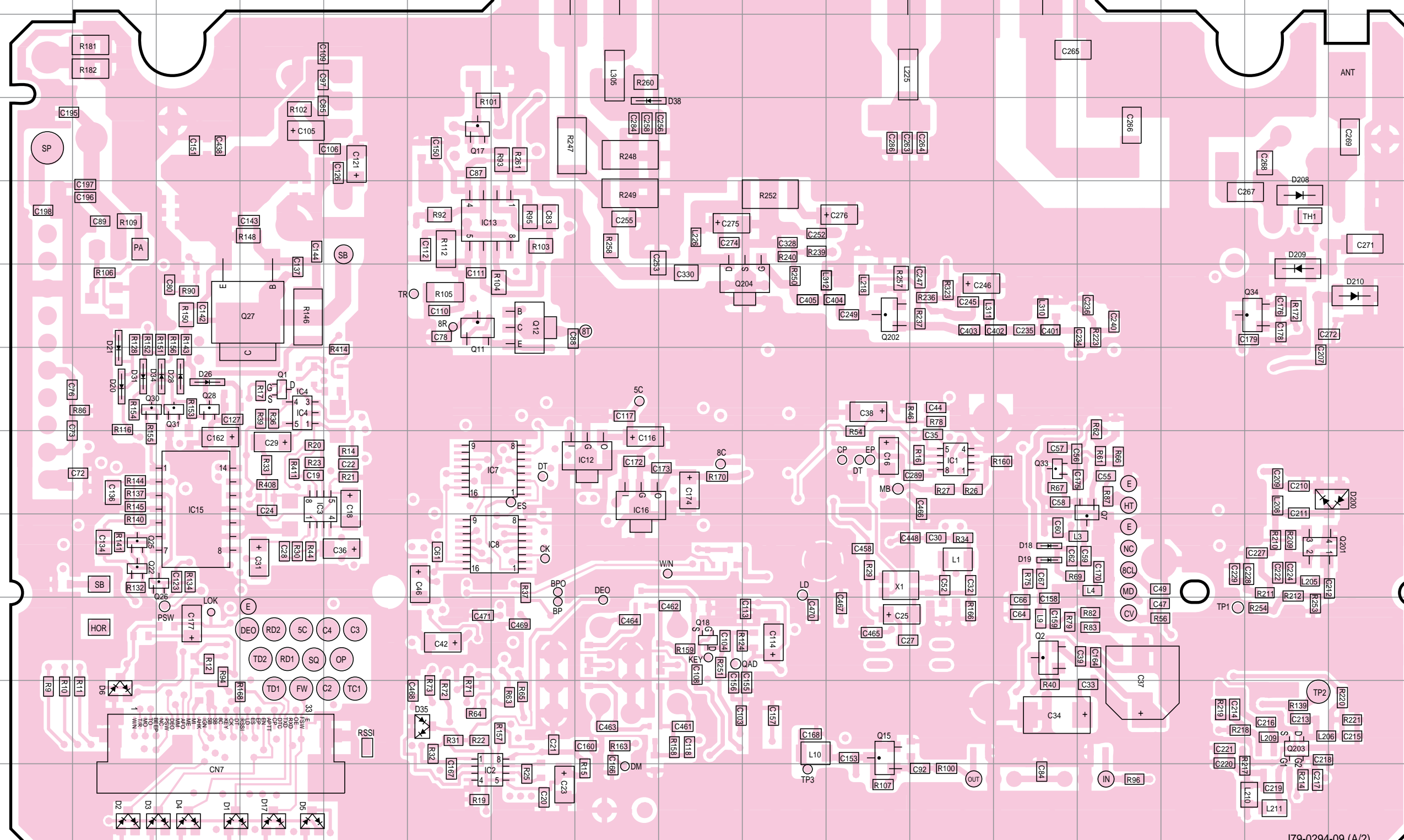

Ref. No.	Address
IC1	9L
IC2	13F
IC3	9D
IC4	8D
IC7	9G
IC8	10G
IC12	9H
IC13	6F
IC15	9C
IC16	9H
IC400	2J
Q1	8D
Q2	11M
Q7	9N
Q11	7F
Q12	7G
Q15	12K
Q17	5F
Q18	11I
Q22	10B
Q25	10B
Q26	10C
Q27	7D
Q28	8C
Q30	8B
Q31	8C
Q33	9M
Q34	7P
Q201	10P
Q202	7K
Q203	12P
Q204	7J
D1	13C
D2	13B
D3	13C
D4	13C
D5	13D
D6	12B
D17	13D
D18	10M
D19	10M
D20	8B
D21	8B
D26	8C
D28	8C
D31	8B
D34	8C
D35	12F
D38	5H
D200	9Q
D208	6P
D209	7P
D210	7Q

J79-0294-09 (A/2)

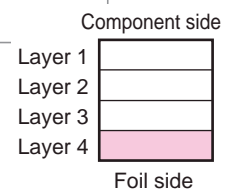

TK-980/981 PC BOARD

TX-RX UNIT : CONTROL SECTION (X57-6520-XX)(B/2) -12 : TK-980 -13 : TK-981
Component side view (J79-0294-09 B/2)

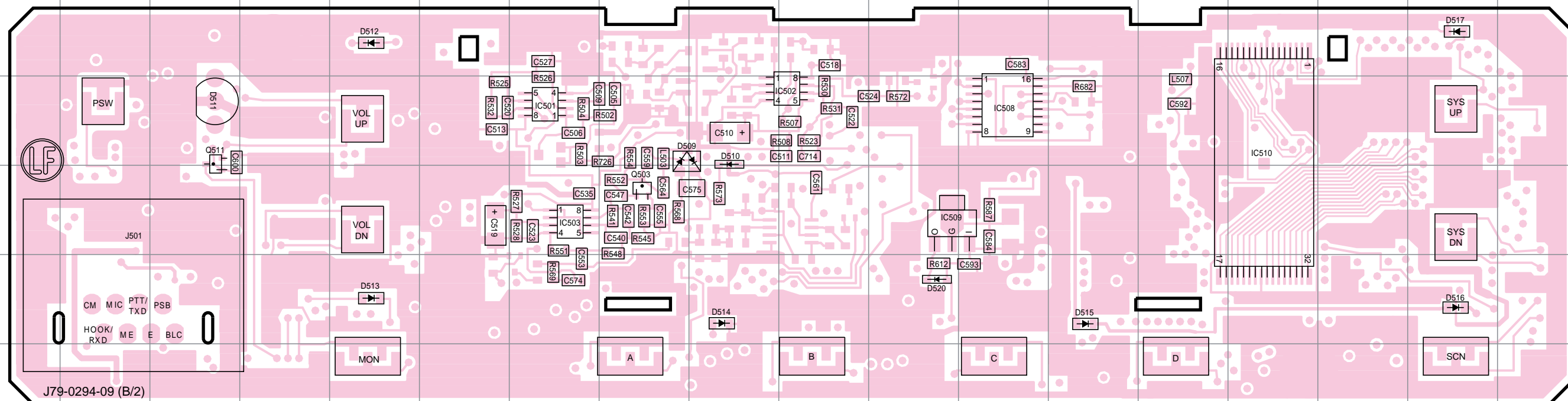

Ref No.	Address	Ref No.	Address	Ref No.	Address	Ref No.	Address
IC501	2G	IC510	3O	D511	3C	D516	5Q
IC502	3J	Q503	4H	D512	2E	D517	2Q
IC503	4G	Q511	3C	D513	5E	D520	5K
IC508	3L	D509	3H	D514	5I		
IC509	4K	D510	3I	D515	5M		

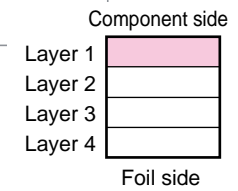

Foil side view (J79-0294-09 B/2)

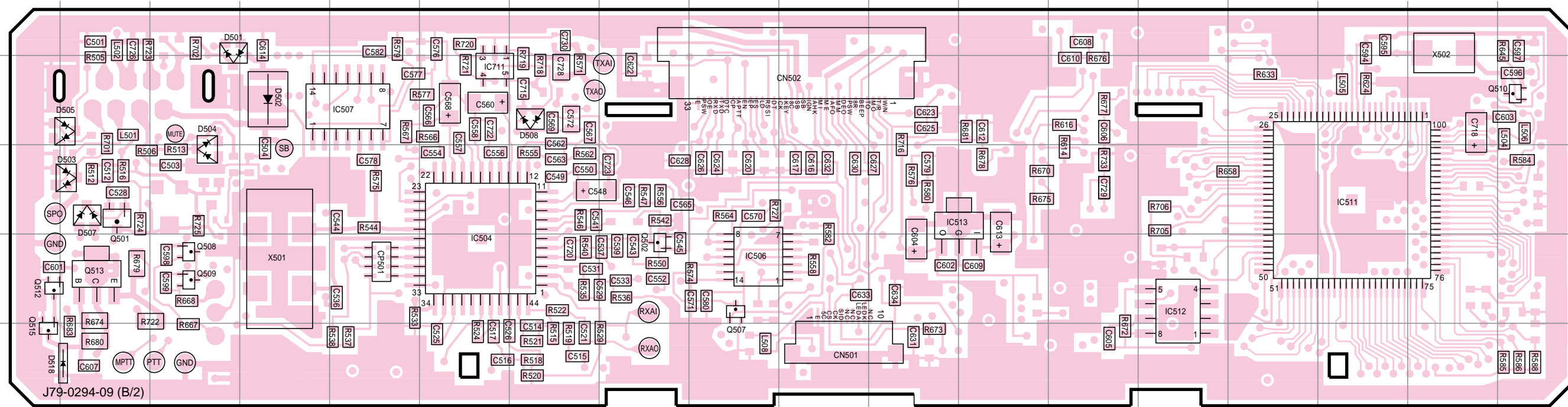

Ref No.	Address	Ref No.	Address	Ref No.	Address	Ref No.	Address	Ref No.	Address
IC504	11F	IC513	10L	Q508	11C	Q515	12A	D505	9B
IC506	11I	IC711	8F	Q509	11C	D501	8C	D507	10B
IC507	9E	Q501	10B	Q510	9R	D502	9D	D508	9G
IC511	10P	Q502	11H	Q512	11A	D503	10A	D518	12A
IC512	11N	Q507	11I	Q513	11B	D504	10C		

